



A Halma company

More Efficient Flow Control for Bioreactors and Bioprocess Systems

A demonstration of reducing cost and complexity of bioreactor gas inputs utilizing high controllable range, multi-gas, differential pressure based mass flow controllers

Mic Chaudoir, Ph.D.

Alicat Scientific Market Manager, Bioreactors

Chip Stacy

AbbVie Senior Engineer of Digital Systems



As the need for even more potent and specific pharmaceuticals grows, pharmaceutical manufacturers have turned to biologics to meet increasing needs to solve complex and currently untreatable conditions (including cancer and myriad genetic diseases). Biologics and biosimilars differ from conventional drugs in that they are grown in living cells, rather than manufactured using chemical processes. This growth is carried out in a controlled environment typically termed a bioreactor or fermenter. The bioreactor environment poses some unique challenges to process and automation experts. The bioprocessing techniques required utilize sophisticated control schemes, specific materials and complex gas control systems. As the organisms grow, mass flow needs within the reactor can scale exponentially, more than in most common chemical and industrial processes.

The diagram to the right shows a typical gas input schema for a global premier biologics manufacturer. Note that this design requires high-flow and low-flow lines for both oxygen and process air. This multiplicity of mass flow lines shown is required by the limited controllable range of the mass flow controllers used. For example, the oxygen flow lines show one controller to be used for flow rates under 35 SLPM and another for flow rates under 100 SLPM. These flow ranges imply a controllable range of no more than 50:1 for the controller specified. Alicat recommended that this design could be simplified by utilizing Alicat's mass flow controllers. The latest Alicat mass flow controllers have a controllable range as wide as 10,000:1, far in excess of the 30:1 requiring a dual flow range design, and improved from the 200:1 previously available.

Bioreactors typically have feed pressures of approximately 50 Psig or less. **Table 1** shows the flow rate error of a standard Alicat Bio-Series 10 SLPM (standard liters per minute) controller when turned down from 10 SLPM to 1 SCCM under typical conditions.

ORIGINAL FLOW DIAGRAM

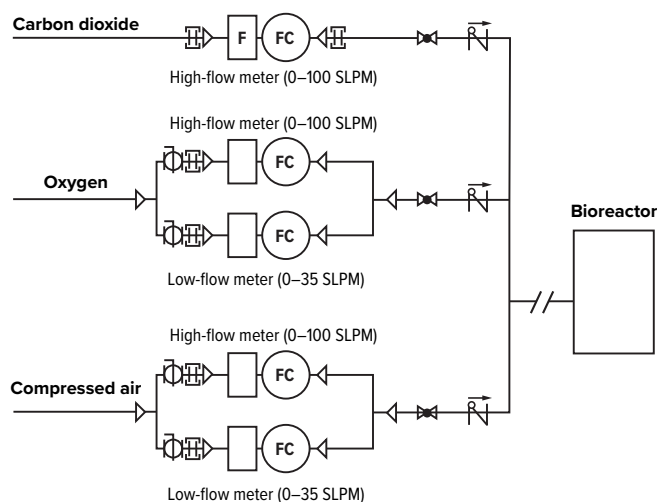

Figure 1: Piping and instrumentation diagram for the original gas input schema of a bioreactor.

SIMPLIFIED FLOW DIAGRAM

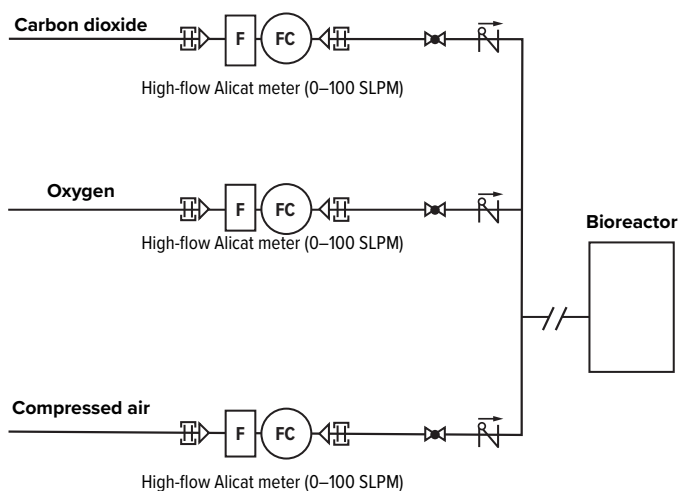

Figure 2: Simplified piping and instrumentation diagram for gas input into a bioreactor, using Alicat flow meters with high controllable ranges.

Desired Flow Rate (SLPM)	Flow Rate Error (SLPM)	Error as % Flow
10.0	+/- 0.06	0.6%
1.0	+/- 0.01	1.0%
0.1	+/- 0.01	10.0%
0.01	+/- 0.01	100.0%
0.001	+/- 0.01	1000.0%

Table 1: Alicat mass flow accuracy vs. flow rate for a typical Alicat BIOC 100 SLPM Mass Flow Controller

Virtually any modern mass flow controller can be adequate within the middle and top of their specified flow range, regardless of the measurement technology used. The Alicat mass flow controller has a mass flow error of only 0.6% near the top of the scale, and only 1% error at 1 SLPM. What enables the flow range simplification discussed is the high degree of accuracy at very low flows. An Alicat MFC has an error of less than 10% of the desired flow rate at a turndown of 100:1. Even as low as 1000:1 the error in flow is only 0.01 SLPM for a 10 SLPM flow controller. The data indicates that this biologics manufacturer could reduce the total lines needed for this design from 5 lines to 3 by using an Alicat mass flow controller with a differential pressure based measurement technique. This allows for a 33% cost savings in parts, construction time and control systems for this portion of the bioreactor. All the while simplifying the design, increasing redundancy and decreasing the number of potential failure points.

Many of the above advantages are enabled by Alicat’s laminar flow measurement technology. In addition to providing very high controllable ranges, this technology is also equally accurate for any gas controlled; there is no need for imprecise K factors or other compensation techniques. This means fewer spares are needed, since any unit can work equally well with any gas. Changing gases via Alicat’s “gas select” feature is easily done from the unit’s front touchscreen. All with no loss of accuracy or need for re-calibration.

Other mass flow controllers commonly use thermal measurement technology. While this method has stood the test of time (dating back to 1911), thermal units cannot respond quickly, as the sensor mass needs to change in temperature to change reading. While newer thermal designs respond faster due to predictive algorithms, Alicat’s differential pressure method can respond to control changes as fast as 25ms – about 50X faster. Thermal units are also sensitive to process water contamination, as the presence of water effects the measurement and calibration of the heated flow sensor. Alicat mass flow technology is relatively insensitive to transient contamination with water (see our previous experiment demonstrating this).

Alicat’s mass flow controllers and meters also provide other features enabling superior accuracy and ease of use. Units can be calibrated either in place, or on-site, using available Alicat software and calibration standards. This calibration procedure is the same regardless of how the units are controlled; analog, digital or via industrial protocol. Under these same conditions, an Alicat flow controller can also report multiple parameters, simultaneously. For example, an Alicat flow controller can output mass flow, pressure, valve drive voltage and temperature – all at the same time. For ease of troubleshooting and testing, units also have a built in full color TFT display that can be rotated 180 degrees, as well as control via a built in keypad.

Alicat’s controllers and meters enable simple and efficient designs. And the Bio-Series does so with options for a fully BPE compliant design, certified USP VI elastomers, your choice of industrial protocol and much, much more. Choose the unprecedented controllable range in the latest Alicat series mass flow controllers and meters to reduce your bioprocessing costs while increasing system performance and improving reliability.



A **Halma** company



Dr. Chaudoir obtained his degree in Cell and Molecular Biology from Northwestern University in 1997.

He has led product development and marketing at a number of scientific instrument companies including Leica Microsystems, Photometrics and Fiberguide Industries. He joined Alicat Scientific in late 2018 and currently leads Alicat's efforts in the bioreactor and optics markets.



Mr Stacy is an instrumentation and controls engineer at one of the world's foremost biopharmaceutical manufacturers, AbbVie.

His career began with instrumentation training in the U.S. Naval Submarine Service. He then began engineering systems for cell culture growth and support in 2001 with Abbott Laboratories. He continues working to improve controls for bioprocessing for AbbVie.

WORLD HEADQUARTERS:

7641 N Business Park Drive
Tucson, Arizona 85743, USA

Phone: +1 520.290.6060
+1 888.290.6060

Fax: +1 520.290.0109
Email: info@alicat.com
www.alicat.com

EUROPE REGIONAL OFFICE:

Geograaf 24 • 6921 EW Duiven
The Netherlands

Phone: +31 (0) 26 203.1651
Email: europe@alicat.com
www.alicat.com

CHINA AND SOUTHEAST ASIA

REGIONAL OFFICE:

2nd Floor, Block 63, #421 Hong Cao Rd, Xuhui District, Shanghai,
PRC 200233

Phone: +86.21.60407398 ext. 801, +86.21.60167680
Fax: +86.21.54530630
Email: info-cn@alicat.com
www.alicat.com.cn

INDIA REGIONAL OFFICE:

M/s Halma India Pvt. Ltd.
C/O Avire India Pvt. Ltd.
Plot No. A-147, Road No. 24
Next to Spraytech Circle,
opp. Metropolitan Company
Wagale Industrial Estate, Thane (West) 400604, Maharashtra, India

Phone: +91.7507826561
Email: info-in@alicat.com

WITH MANUFACTURERS' REPRESENTATIVES WORLDWIDE