



A Halma company



OPERATING MANUAL

FOR STANDARD FLOW AND PRESSURE DEVICES

Models M · MC · P · PC · L · LC

Thank you for purchasing your Alicat instrument.

If you have any questions, or if something is not working as expected, please contact us. We are eager to help you in any way possible.

Contact Information

**World Headquarters,
Tucson, Arizona, USA**
info@alicat.com
alicat.com
7641 N Business Park Dr.,
Tucson, AZ 85743 USA
+1 888-290-6060

China & SE Asia
info-cn@alicat.com
alicat.com.cn
3rd Floor, Building 18,
FAMILY Science and
Technology Innovation
Park, No. 155, Yuanke Road
Minhang District
Shanghai, PRC 201109
+86 21-6151-9020

Europe
europa@alicat.com
Geograaf 24
6921 EW Duiven
The Netherlands
+31(0) 26 203.1651

India
india@alicat.com
Alicat Scientific India Pvt. Ltd.
101, Hamilton A Bldg,
Near Hiranandani Hospital,
Hiranandani Estate, Patli
Pada, Ghodbunder Road,
Thane West-400607
Maharashtra, India
+91 22460-81434

Recalibrate your instrument every year.

Annual calibration is necessary to ensure the continued accuracy of readings, and to extend the Limited Lifetime Warranty. Fill out the Service Request Form at alicat.com/service, or contact us directly when it is time to send in your instrument for recalibration.

For instruments ordered with CSA, ATEX, ISO 17025, or other certifications, please visit alicat.com/certifications. For information about our limited lifetime warranty, visit alicat.com/warranty.

Serial #:

Next Calibration:



This instrument comes with a NIST-traceable calibration certificate.



This instrument conforms to the European Union's Restriction of Use of Hazardous Substances in Electrical and Electronic Equipment (RoHS) Directive 2011/65/EU.



This instrument complies with the requirements of the EMC Directive 2014/30/EU: EN 51326-1:2013 and the RoHS Directive 2011/35/EU: EN 63000:2018, and carries the CE Marking accordingly.



This instrument complies with the requirements of the Electrical Equipment (Safety) Regulations 2016 and the Electromagnetic Compatibility Regulations 2016 and carries the UKCA marking accordingly.



This instrument complies with the requirements of the European Union's Waste Electrical & Electronic Equipment (WEEE) Directive 2012/19/EC

MC-10SLPM

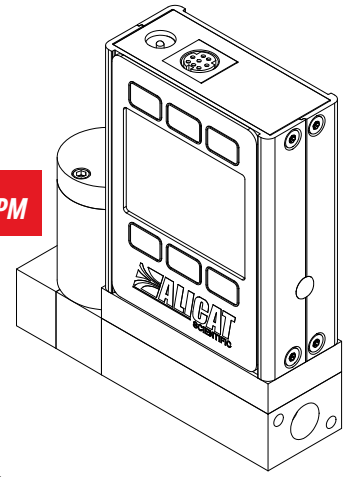

PC-PSIG

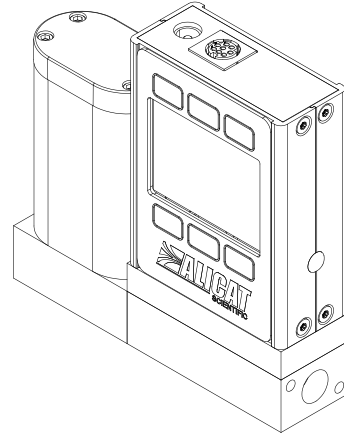

LB-1LPM

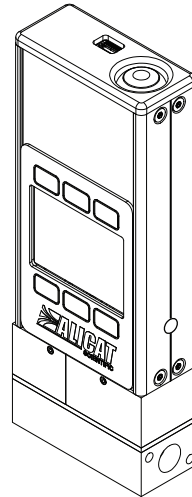

MCES-2SLPM

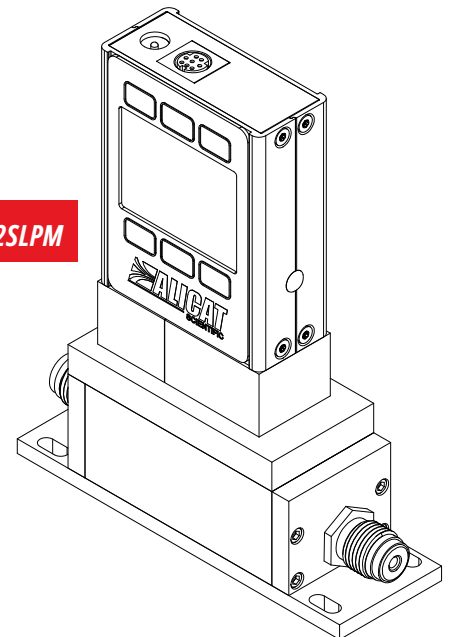

Introduction

Depending on the model, Alicat instruments have a variety of innovative features:

- **1000 readings per second** guarantees high resolution data.
- **High-accuracy performance for all your flow.** Use the mass flow instruments with any of the 98+ gases included with Gas Select™ ([page 25](#)).
- **Control pressure while monitoring flow rate.** Set the closed loop control algorithm to pressure control on your mass flow or liquid controller ([page 22](#)).
- **Control either gas or liquid** with your pressure controller.
- **Monitor live pressure and temperature** in mass flow or liquid processes ([page 11](#)).
- **Autotuning optimizes the control response** to the current process conditions ([page 21](#)).
- **Backlit display with adjustable contrast** is easy to read even in direct sunlight. In dimly lit areas, press the logo to turn on the backlight ([page 11](#)).
- **Change your STP** to match any standard temperature and pressure reference for your mass flow ([page 28](#)).
- **Log data to your PC** with a serial data connection to control the instrument and capture data for logging and analysis ([page 33](#)).

This manual covers the following instruments among others:

- **Standard:** M, MC, P, PC, L, LC
- **Low pressure (Whisper™):** MW, MWB, MCW
- **High pressure:** MQ, MBQ, MCQ
- **Anti-corrosive:** MS, MBS, MCS, PS, PBS, PCS, LS, LBS, LCS
- **Portable battery-powered:** MB, MBS, MWB, MBQ, PB, PBS, LB, LBS
- **Dual valve:** MCD, PCD
- **Other variants:** MCE, MCV, PCP, PC3, IVC

For support or questions regarding the use or operation of this instrument, please contact us using the information on [page 2](#).

Alicat offers many combinations of instrument sizes, accessories, connections, and configurations. These custom solutions can meet a variety of application challenges brought forth by users pushing the boundaries of our standard offerings. If you have an idea for a new process or a challenging application, contact Alicat for specialized engineering and application support.

This manual covers the general operation of factory OEM instruments. Custom setups may not be covered by this document. If you need further assistance, please contact Alicat support.

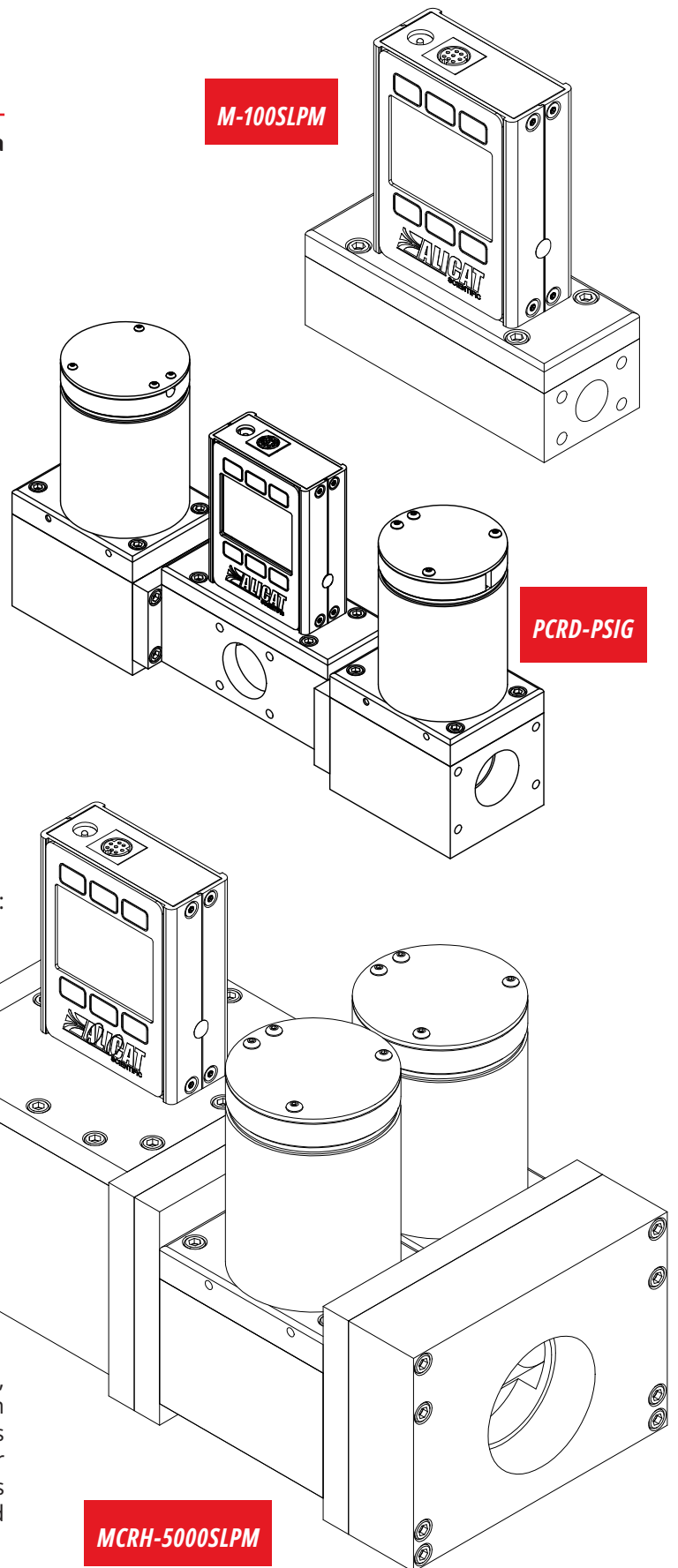

Contents

Introduction	3	Instrument Setup	25
Quick Start Guide	6	Gas Selection Mass Flow Instruments	25
Installation and Startup	7	Gas Select™	25
Safety Warnings	7	COMPOSER™ Gas Mixes	25
Installation	7	Creating New Mixes in COMPOSER™	26
Filters	8	Viewing, Deleting, and Creating Similar Mixes	26
Power and Signal Connections	8	Sensor Setup	26
Analog Signals	9	Engineering Units	26
Option: Charging a Portable Meter or Gauge	9	Totalizer Options Flow Instruments	27
Bleed Ports Liquid Instruments	10	STP/NTP Reference Values Mass Flow Instruments	28
Basic Operations	11	Flow and Pressure Averaging	29
Taring the Instrument	12	Zero Band	29
How to Tare	12	Serial Communication Configurations	29
When to Tare	12	Unit ID	29
Changing the Setpoint Controllers	12	Stream	29
Selecting Gas Mass Flow Instruments	13	MODBUS RTU Address	29
Data Screens	14	Baud Rate	30
Live Screen	14	Manage Setpoint when Connection is Idle Controllers	30
Min/Max Screen	14	Signals	30
Totalizer Screens Flow Instruments	14	Display Setup	30
Option: Color TFT Display	15	Data Screens	30
Instrument Information	16	Screen Lighting	31
Basic Instrument Information	16	Display Rotation	31
Instrument Full Scale Ranges	16	Advanced Setup	31
Manufacturer Information	16	Digital Control	32
Process Control Controllers	17	FlowVision 2.0	32
Setpoint	17	Establishing Communication	32
Setpoint Options	17	Serial ASCII Communication	33
Autotare and Zero Setpoint Options	17	Establishing Communication	33
Setpoint Source	17	Alicat's Serial Terminal Application	33
Idle Connection Response	18	Unit ID	33
Setpoint on Power-Up	18	Taring the Instrument	33
Setpoint Limits	18	Collecting Data	34
Setpoint Ramping	18	Data Format	35
Ramp Rate	18	Setpoint Controllers	35
Ramping Options	19	Check Control Flow and Pressure Controllers	35
Batch Dispensing Flow Controllers	19	Optimize Control (Autotune) Flow Controllers	36
Start a Batch	19	Gas Select™ and COMPOSER™ Mass Flow Instruments	37
Repeat a Batch	20	Quick Command Reference	38
Pause or Cancel a Batch	20	MODBUS RTU Communication	39
Valve Drive Percentage Display	20	Troubleshooting	40
Check Control Controllers	20	Mass Flow Instruments	40
Optimize Control (Autotune) Flow Controllers	21	Maintenance	42
Advanced Configuration Options	21	Cleaning	42
Control Loop	22	Repair	42
Controlled Variable	22	Recalibration	42
PD/PDF or PD ² I Control Algorithms	22		
Flow Limit while Controlling Pressure Flow Controllers	23		
Gas Adjust Mass Flow Controllers	24		
Control Deadband for Pressure Control	24		

Appendix A: Pinouts	43
8-Pin Mini-DIN (Default)	43
Locking Industrial Connector Pinout	43
9-Pin D-Sub Connector Common Pinouts	44
15-Pin D-Sub Connector Common Pinouts	44
M12 Connector Common Pinouts	45
Appendix B: Reference Information	46
Engineering Units	46
Gas List by Number	47
Gas List by Category	48
Appendix C: Application Setup	49
MCV Controller Operating Notes	49
Pressure Controller Applications	49
Forward (Downstream) Pressure Control	49
Back Pressure Control	50
Dual Valve Pressure Control	50
Differential Pressure Control	50
Remote-Sensing Controller	51
Integrated Vacuum Controllers (IVC)	51

Quick Start Guide

Setup

- **Connect your instrument.** Ensure that flow passes through your instrument in the same direction as the arrow on the flow body (usually left to right). Application setup examples can be found in Appendix C ([page 49](#)).
- **Choose your engineering units.** You can choose the measurement units by selecting **MAIN MENU** → **SETUP** → **Sensor** → **Engineering Units**. See [page 26](#) for more details.

Operation: Flow Verification

- **Monitor live flow, temperature, and pressure readings.** Readings are updated and displayed on your instrument in real time. See [page 11](#).
- **Capture totalized readings.** The totalizer option displays the total flow that has passed through the instrument since the last time the totalizer was reset. To enable the totalizers, press **MENU** → **SETUP** → **Sensor** → **Totalizer 1** or **Totalizer 2**. See [page 27](#).

Connectors and Buttons

The drawing to the right represents a typical configuration of a standard controller. **Your instrument's appearance and connections may differ.**

Backlight

The monochrome display comes equipped with a backlight. **To toggle the backlight power, press the logo on the front of your instrument.**

For optional color TFT displays, pressing this button turns off the display to conserve power. See [page 6](#).

Maintenance and Care

- Gas instruments do not require cleaning when flowing clean, dry gases. Liquid instruments require minimal cleaning when flowing clean liquids ([page 42](#)).
- Calibrate your instrument annually. To schedule a calibration, please contact support ([page 2](#)).

This MC-1SLPM-D model mass flow controller is a typical unit. The flow body and the valve sizes can vary significantly.

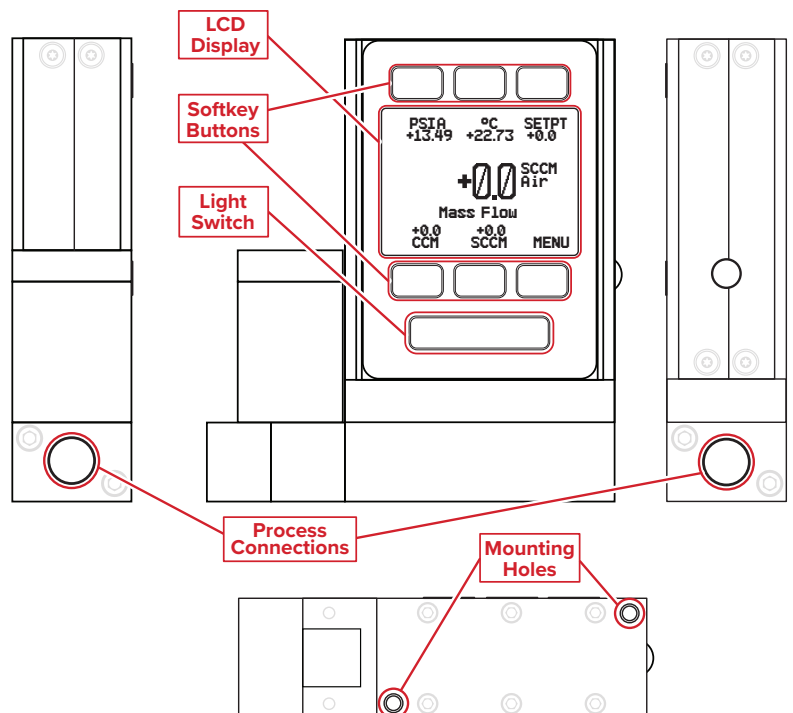
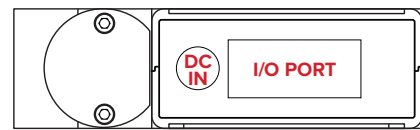
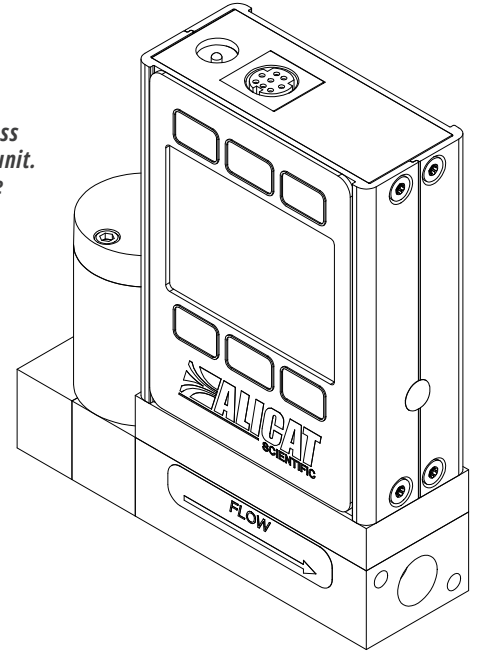

Installation and Startup

Safety Warnings

- For assistance in performing any disassembly of the instrument, please contact Alicat support ([page 2](#)) for assistance.
- Operating this instrument under conditions which exceed the specifications noted in the manual or specification sheet could lead to equipment damage or injury.

Installation

The instrument does not require straight runs of pipes either upstream or downstream. It can operate in any orientation whether it's on its side, laid on its back, or inverted and operating upside down. Controllers with Rolamite valves are the only exception. Rolamite valves need to be oriented vertically, but they can be configured so that the flow body is connected in a different direction.

Be sure to reference your instrument dimensions to determine the size and positions of the mounting holes on the bottom of the instrument.

1. Mount the instrument so that flow passes through the flow body as indicated by the arrow or left to right if an arrow is not present. Refer to the instrument specifications at alicat.com/specs for dimensions and mounting options.
2. Remove any plastic plugs from the inlet, outlet, or process connections.
3. Plumb appropriate lines to the inlet and outlet connections (and process connection, if present). For pressure controllers, refer to Appendix C ([page 49](#)) for diagrams on plumbing specific controllers.

Face seal fittings do not need Teflon tape on the threads.



Do not use pipe dopes or sealants on the process connections. These compounds can cause permanent damage to the instrument should they get into the flow stream.

For fittings without face seals, use thread-sealing Teflon tape to prevent leakage around the connections.



Do not wrap the first two threads entering the instrument. This minimizes the possibility of getting tape into the flow stream and clogging or damaging the instrument.

4. Connect cables to the power and signal connectors (may not be applicable to battery instruments).
5. Enable power to the instrument. The instrument automatically turns on once it is connected to power.



Do not enable power to the instrument until all necessary pins have been confirmed to be properly connected.

The instrument is now ready for use. For further instruction and operation of your instrument, please read further.

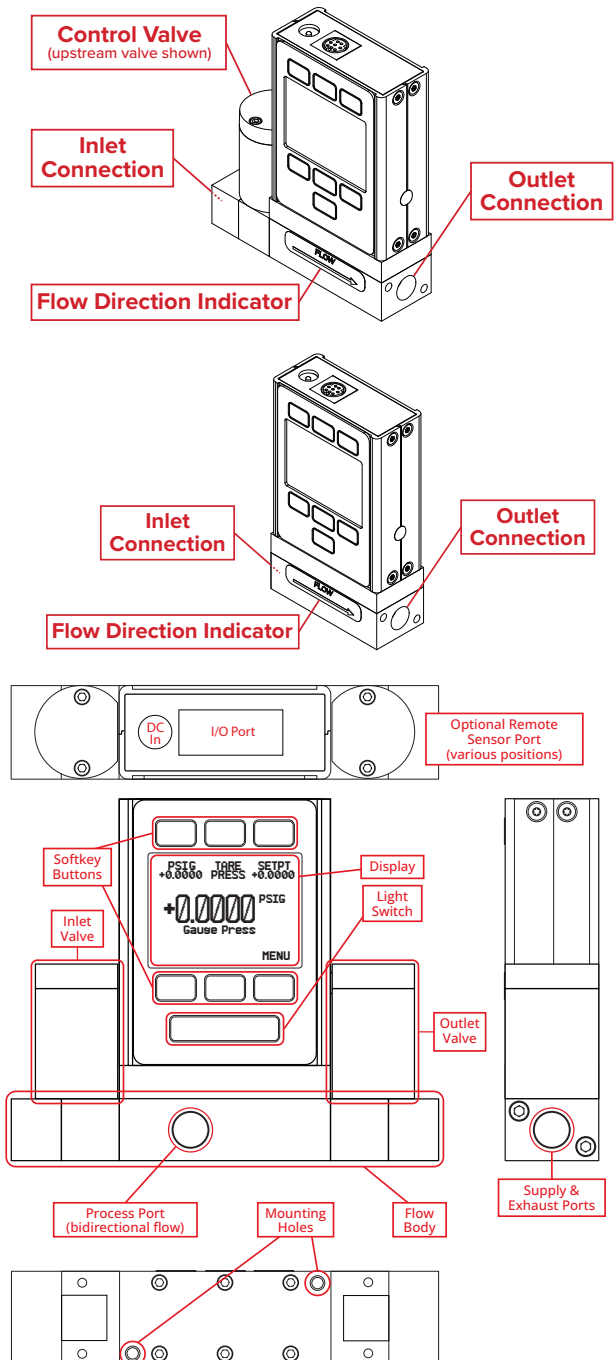

Filters

When pressure drop is not a concern, use in-line sintered filters to prevent large particulates from entering the flow body of the controller. Suggested maximum particulate sizes are as follows:

Mass Flow:

- **5 microns** for instruments with flow ranges ≤ 1 SCCM.
- **20 microns** for instruments with flow ranges between 1 SCCM and 1 SLPM.
- **50 microns** for instruments with flow ranges ≥ 1 SLPM.

Liquid:

- **20 microns** for instruments with flow ranges ≤ 100 CCM.
- **40 microns** for instruments with flow ranges > 100 CCM.

Pressure:

- Maximum **40 microns** for all gauges.
- **20 microns** for PC, PCD, PCP, PCPD, PCH, PCHD, PC3, PCD3
- **40 microns** for PCR, PCRD, PCR3, PCR3D

Power and Signal Connections

Power can be supplied to your instrument through either the power jack or the multi-pin connector on top of your instrument.

For more pinout configurations, see [page 43](#).

Note: Power requirements vary based on analog configuration and valve type. Please reference the associated specification sheet at alicat.com/specs for power requirements.



Warning: Do not connect power to pins 1 through 6, as permanent damage can occur. It is common to mistake pin 2 (labeled 5.12 Vdc Output) as the standard 0–5 Vdc analog output signal. Pin 2 is normally a constant 5.12 Vdc.

8-Pin Mini-DIN Pinout

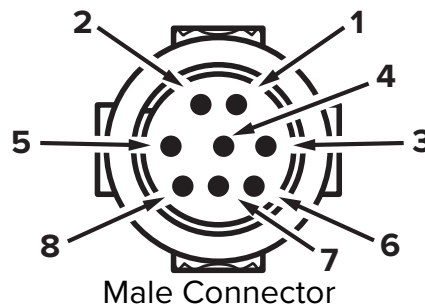
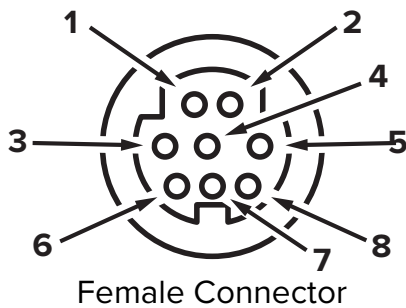

Pin	Function
1	Not Connected <i>Optional: 4–20 mA primary output signal</i>
2	Static 5.12 Vdc by default. <i>Optional: secondary analog output (4–20 mA, 0–5 Vdc, 1–5 Vdc, 0–10 Vdc) or alarm</i>
3	Serial RS-232 RX / RS-485 B(+) Input Signal (receive)
4	Controllers: Analog Setpoint Input Meters: Remote tare (ground to tare)
5	Serial RS-232 TX (send output) / RS-485 A(-)
6	0–5 Vdc <i>Optional: 1–5 Vdc or 0–10 Vdc output signal</i>
7	Power In (as described above)
8	Ground (common for power, digital communications, analog signals, and alarms)

The above pinouts are applicable to all instruments with the mini-DIN connector. The availability of different output signals depends on the options ordered. Optional configurations are noted on the unit's calibration sheet.

Analog Signals

Primary Analog Output Signal

Most instruments include a primary analog output signal that is linear over its entire range. For ranges that start at 0 Vdc, a zero-pressure or no-flow condition is indicated at approximately 0.010 Vdc. Full scale of the instrument is indicated by the top of the range: 5 Vdc for 0–5 Vdc, 20 mA for 4–20 mA signals, and so on.

Option: Secondary Analog Output Signal

The default 8-pin mini-DIN connector places the secondary analog output on pin 2 for both voltage and current signals. Your instrument's secondary analog signal may differ from its primary output signal.

A calibration sheet ships with the instrument showing which output signals were ordered.

Option: 4–20 mA Current Output Signal

If the instrument has a 4–20 mA current primary or secondary output signal, it requires at least 12 Vdc power.

Warning: Do not connect 4–20 mA instruments to “loop powered” systems, as this damages portions of the circuitry beyond repair and voids the warranty. If the instrument must interface with existing loop powered systems, use a signal isolator and a separate power supply.

Using Ground to Tare (Meters and Gauges)

You can tare your meter or gauge remotely by momentarily grounding the remote tare pin (pin 4 on the Mini-DIN connector). When the switch is closed, the instrument tares. Operation resumes when the switch is released. You can also tare with the front controls (page 12) or serial commands (page 33). Taring flow should only be done in a true zero-flow condition and taring pressure should be done when the instrument is open to the atmosphere.

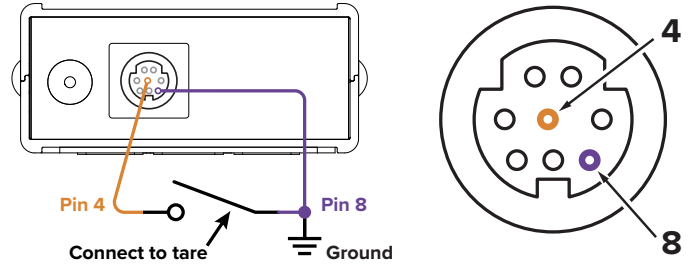

Option: Charging a Portable Meter or Gauge

Portable batteries are partially charged before shipping. When fully charged, the typical battery life is 18 hours with a monochrome display, or 8 hours with a TFT color display. Dimming the backlight increases battery life. When the battery indicator displays as completely empty, about 15 minutes of battery life remain.

Charge the instrument using the supplied USB cable (micro-B to type A) or a similar cable. Any USB outlet on a computer or portable power supply may be used, but charging is fastest (approximately 3.5 hours) when using the supplied 2.0 A power supply.

The red indicator LED on top of the instrument lights up to indicate that the unit is charging, and turns off when the battery is fully charged.

Your meter may be used while it is charging. If the battery has been fully depleted, you may need to charge the meter for a full minute before the instrument can be turned on.

Warning: The safe charging temperature range is 0–45°C (32–113°F). If internal sensors detect temperatures outside of this range, the battery will not charge.

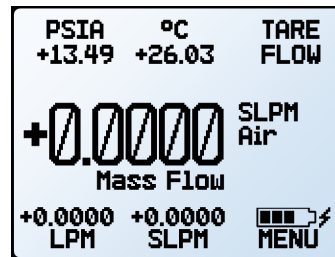

Main display with battery information and an active charging indicator (lightning bolt).

Liquid instruments include bleed ports (8-32 Nylon-tipped screw) on the front for the removal of air bubbles.



Note: A small amount of liquid will leak from the instrument during this procedure. Take necessary precautions to prevent damage to anything nearby.

Bleed both of the ports as follows:

1. With the instrument installed, start a flow greater than 50% of full flow. Gently loosen the upstream bleed port screw 1 to 2 turns, or until liquid begins to leak from the threads. **Do not remove the screw**, as it has pressure behind it, is very small, easy to lose, and delicate to re-thread.
2. Gently tap the flow body to remove air bubbles (screwdriver handles work well). This may not be visible or audible.
3. Gently tighten the screw until the leakage stops, taking care not to crush the nylon tip.
4. Repeat steps 1–3 with the downstream port.



Note: If your instrument is mounted in an inverted position, avoid using the bleed screws, as liquid may leak and cause permanent damage.

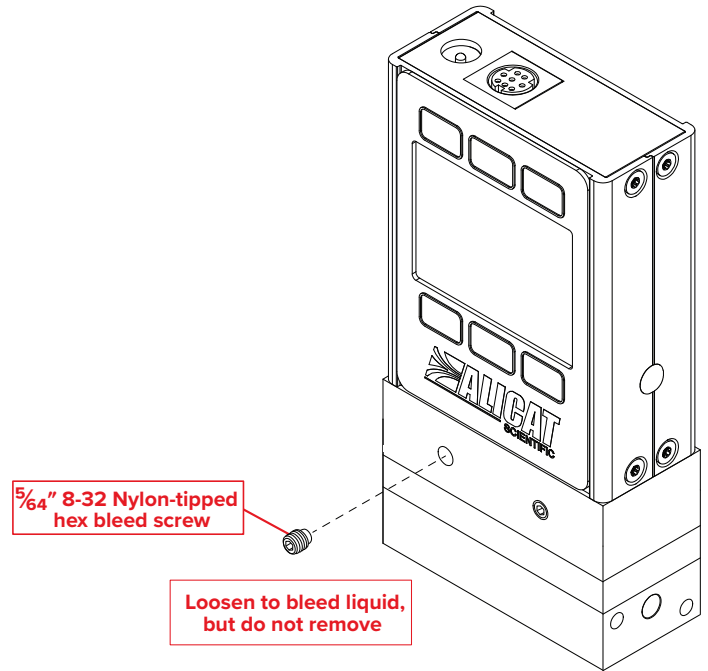

Basic Operations

This section covers your instrument's most common functions. Settings for more specialized needs can be found after this section. Some information found in this section may be repeated in other sections for ease of section navigation.

Viewing Live Data

The display screen has a number of options for displaying live data. There are various ways to modify the display screen functions, brightness, or orientation. Refer to **display setup** (page 30).

The display screen displays live data for all parameters measured by the instrument simultaneously. Sensors measure data 1000 times per second and the LCD display updates 10 times per second. The measured data is displayed in the units designated by the instrument (page 26).

Interacting with the Instrument

The images to the right show the instrument display buttons. These images compare the differences between a mass flow controller, a pressure controller, and a liquid meter.

Below are the default button functions and their locations. Pressing a button to highlight a reading changes what is centered in the display.

- **Highlight pressure:** all instruments use **button 1**.
- **Highlight volumetric flow:** mass flow and liquid instruments use **button 4**. Pressure instruments do not measure volumetric flow.
- **Highlight mass flow:** mass flow instruments use **button 5**. Pressure and liquid instruments do not measure mass flow.
- **Highlight temperature:** mass flow and liquid instruments use **button 2**. Pressure instruments do not measure temperature.
- **Changing the setpoint:** controllers use **button 3**. Meters and gauges do not have a setpoint function. Refer to [page 12](#) for more information on changing the setpoint.
- **Taring the instrument:** meters and gauges use **button 3** (TARE FLOW for meters and TARE PRESS for gauges). Pressure controllers use **button 2**. Mass flow controllers, liquid controllers, and PSIA controllers without a barometer do not have a tare button on the default display. Refer to [page 12](#) for further information on taring.
- **Enter the menu or move to the next screen:** all instruments use **button 6**.
- **Enable/Disable the backlight:** all instruments use **button 7**.

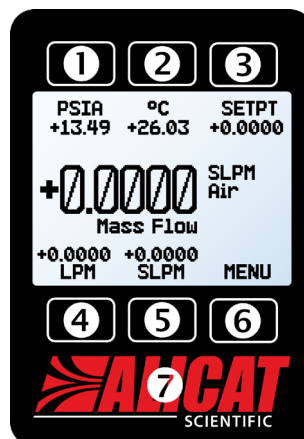

Main display of a mass flow controller measuring the mass flow of air.

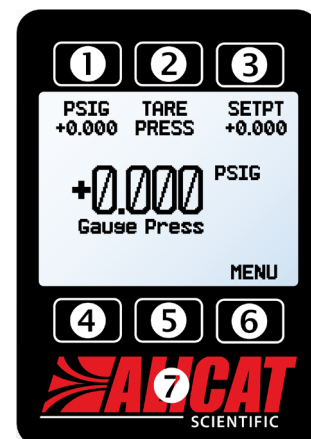

Main display of a pressure controller measuring gauge pressure.

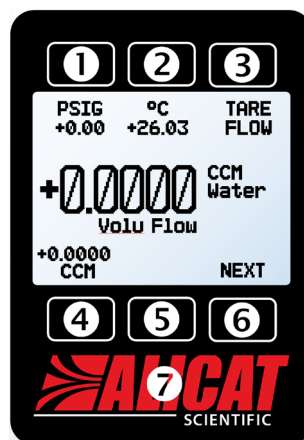

Main display of a liquid meter measuring the volumetric flow of water.

Some instruments do not use all 7 buttons. If an unused button is pressed, nothing happens. Button functions can be modified under **display setup** (page 30).

Status Messages

Status messages are shown to the right of the highlighted central measurement:

ADC Analog-digital converter error	OVR Totalizer rolled over to zero
COM Digital connection has been idle too long	POV Pressure over range of instrument
EXH Exhaust mode active (Controllers only)	TMF Totalizer missed out-of-range flow
GTA Control optimization in progress (Controllers only)	TOV Temperature over range of instrument
HLD Valve hold active (Controllers only)	VOV Volumetric flow over range of instrument
LCK Front display is locked	
MOV Mass flow over range of mass flow instrument	

Taring the Instrument

Taring is an important practice that ensures your instrument provides its most accurate measurements. This function gives a zero reference point for measurements. For instruments installed with a barometer, the absolute pressure reading can be tared when venting to the local barometric pressure.

On mass flow meters, liquid meters, and pressure controllers/gauges, the tare button is found on the main screen. **Button 3** for meters and gauges and **button 2** for pressure controllers. To access taring for mass flow and liquid controllers, press the **MENU** button and then the **TARE FLOW** option.

Depending on the instrument, there may be options for multiple tares (usually flow and liquid instruments with a barometer).

It is also possible for controllers to autotare when the setpoint is at zero for a designated time ([page 17](#)).

How to Tare

Taring Flow *Mass Flow and Liquid Instruments*
TARE FLOW or **MENU** → **TARES** → **TARE FLOW**

Taring flow should take place at the expected process pressure with no active flow. When **Tare Flow** is pressed, a message, “**Ensure no flow before pressing TARE**” is displayed on some instruments. If so, press **TARE** to confirm taring the flow.

Taring Pressure
TARE PRESS or **MENU** → **TARES** → **TARE PRESS**

Taring pressure requires the instrument to be open to atmosphere. Absolute pressure tares also require an optional barometer installed at production. When pressed, a message, “**Press TARE when vented to ambient with no flow. Current pressure offset:**” is displayed. Press **TARE** to confirm taring the pressure.

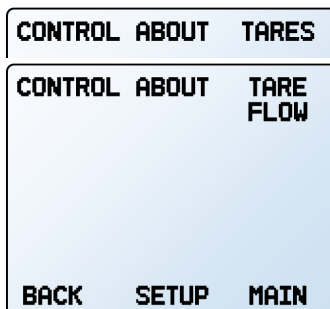

Tare mass flow by selecting TARE FLOW from the main menu (top), or TARES if the device has a barometer (above).

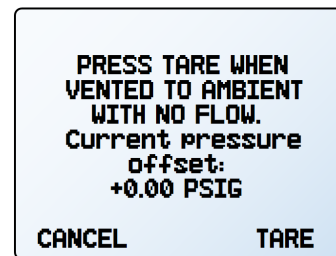

Tare pressure confirmation screen.

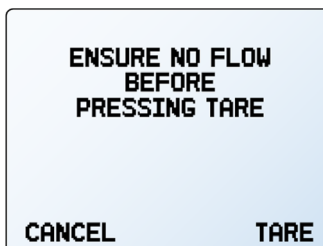

Tare flow confirmation screen.

When to Tare

- After installation
- when changing the instrument's orientation
- if the instrument is hit with any significant impact
- after any significant changes to the temperature or pressure.

Changing the Setpoint *Controllers*

Setpoints manage how much flow passes through the instrument or the pressure level in the system. Pressing the setpoint button from the main screen (**button 3**) moves the screen to the setpoint selection screen.

The setpoint selection screen indicates the engineering units and maximum allowable setpoint (e.g., **SLPM: +1.000 Max**). To establish a setpoint, enter the desired value and press **SET**. The instrument immediately begins to control the flow or pressure.

To give a zero setpoint, press **CLEAR** and then **SET**.

For more detailed options and settings, including setpoint ramping, see [page 17](#).

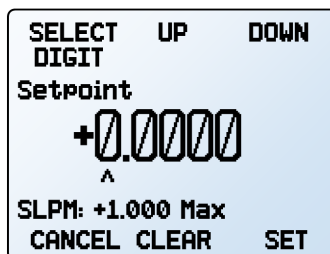

Setpoint selection screen.

MENU → SETUP → Active Gas

In most cases, mass flow instruments are physically calibrated at the factory using air. Gas Select™ allows you to reconfigure the instrument to flow a different gas without any need to send it back for a physical recalibration.

Gas selection is found in the setup menu. To access the menu, press **MENU** and then **SETUP**. When the cursor is pointing at **Active Gas**, press **SELECT**.

Within this menu, there are a variety of gas categories, recent selections, and COMPOSER™ mixes. Each category lists a subset of available gases and pre-configured mixtures. Note that not all gases are available on all instruments. Corrosive gases and refrigerants are only available on the anti-corrosive line of mass flow instruments.

As soon as you press **SET** from the gas list, your instrument reconfigures its flow rate calculations to the newly selected gas properties. There is no need to restart the instrument or perform any other action.

Your current gas selection appears just below the engineering units on the right side of the **main display**.

It is also possible to program the instrument to calculate the mass flow of a custom gas mixture (COMPOSER™ mixes). The instrument can have up to twenty of these mixtures saved at a time. For more information and instructions on creating custom gas mixing, see [page 25](#).

Category and Gas List Controls

- **PAGE** advances the view to the next page of categories or gases.
- **SELECT** (in the category list) opens a list of gases in that category.
- **SET** (in the gas list) immediately loads the gas measurement properties and exits to the **setup menu**.

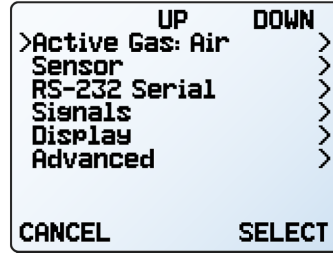

Setup menu.

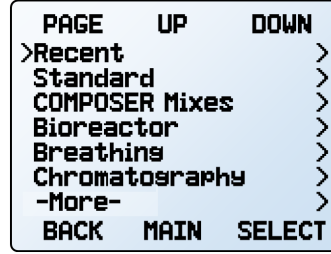

First page of the Gas Select™ category list.

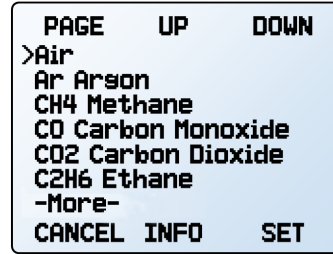

First page of the Gas Select™ standard category.

Data Screens

Depending on the instrument, there can be up to four screens providing different information based on your needs. Further settings for the data screens can be found on [page 30](#).

Live Screen

The **Live screen** is the default data screen of the instrument. This provides access to the different measurements that a instrument may be taking. For more information, see the **Viewing Live Data** section under the **Basic Operations** on [page 11](#).

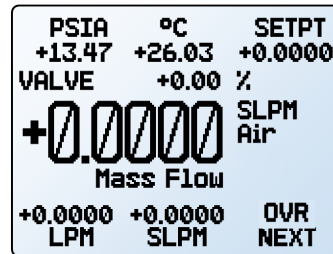

Live screen.

Min/Max Screen

MENU → SETUP → Display → Data Screens → Min/Max Screen

The **Min/Max screen** displays the current selected measurement value as well as the minimum and maximum measurement of that value since the last reset. To enable the screen, change the option from **Hide** to **Show**.

The **Min/Max screen** shows four options:

- **RESET** sets the current measured minimum and maximum to the current value
- **SHOW VALUE** provides possible measurements to display on the screen, along with their minimum and maximum values.

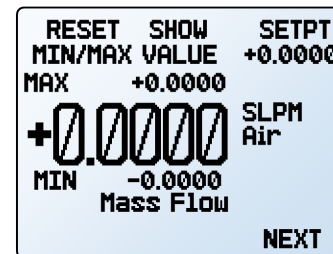

Min/Max screen.

- **SETPT** is only available on controllers. It displays the current setpoint. Press to set or clear a setpoint. See [page 17](#) for setpoint instructions.
- **NEXT** moves to the totalizer screen (if enabled) or **MENU** opens the instrument menu.

Totalizer Screens Flow Instruments

MENU → SETUP → Sensor → Totalizer → Totalizer 1 or Totalizer 2

Mass flow and liquid instruments have optional totalizers that can be configured on the instrument. To enable the totalizer and configure its settings, see [page 27](#). The Totalizer displays the total amount of mass or volume that has flowed through the instrument since its last reset. It also enables batch dispensing for controllers ([page 19](#)).

- **M AVG** or **V AVG** shows totalizer averaging, which displays average flow rate since last reset, updated live.
- **SLPM** (or another measurement of flow) displays the live flow rate.
- **SETPT** displays the current setpoint on controllers. Press to set or clear a setpoint ([page 17](#)).

- **M PEAK** or **V PEAK** displays the peak flow rate since the last totalizer reset (on meters).
- **BATCH** selects the quantity to be dispensed in each batch. **-NONE-** appears if the batch mode is off [page 19](#). Controllers only.
- **RESET** clears all totalized data and immediately resets the timer to 0. This starts a new batch immediately, if the controller has a non-zero setpoint.
- **MENU** enters the **main menu**.
- **NEXT** moves to the second totalizer (if enabled).

Option: Color TFT Display

Instruments ordered with a color display are functionally the same as standard backlit monochrome instruments. The color enables additional on-screen information.

Multi-Color Display Indicators

- **GREEN:** Parameter labels and adjustments associated with the button directly above or below the label are presented in green.
- **WHITE:** Parameters are displayed in white when the instrument is operating within specifications.
- **RED:** Parameters are displayed in red when its value exceeds 128% of the instrument's specifications.
- **YELLOW:** Menu items that are ready to be selected appear in yellow. The color replaces the > symbol in selections on monochrome display.



Note: Press the logo to turn off the color display backlight. The instrument remains in operation while the backlight is off.



Note: Color displays will require an additional 40 mA when using a 12 Vdc power supply. All other specifications from your instrument's specification sheet remain in effect.

To modify the display screen functions, the brightness, or orientation refer to **display setup** ([page 30](#)).



TFT display.

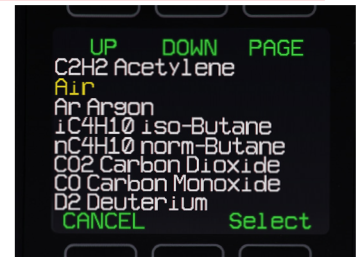

TFT display, air selected in yellow.

Instrument Information

The **ABOUT** menu (**MENU** → **ABOUT**) contains information for setup, configuration, and troubleshooting.

Basic Instrument Information

MENU → ABOUT → About Device

This includes information on the following:

- **MODEL:** Instrument model (character limited—part number may be truncated)
- **SERIAL NO:** Serial number
- **DATE MFG:** Manufacturing date
- **DATE CAL:** Most-recent calibration date
- **CAL BY:** Initials of the person who calibrated the instrument
- **SW:** Firmware version

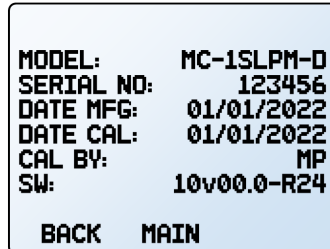

```
MODEL:      MC-1SLPM-D
SERIAL NO:   123456
DATE MFG:    01/01/2022
DATE CAL:    01/01/2022
CAL BY:      MP
SW:          10v00.0-R24

BACK  MAIN
```

About device screen.

Instrument Full Scale Ranges

MENU → ABOUT → Full Scale Ranges

This displays the maximum calibrated range of available flow and pressure readings.

- **Mass flow instruments** include mass flow, volumetric flow, and pressure.
- **Liquid instruments** include volumetric flow and pressure.
- **Pressure instruments** include the various pressures that it can measure.

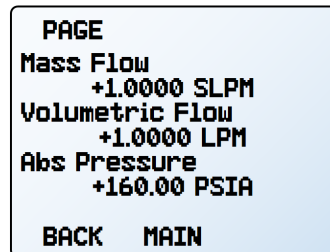

```
PAGE
Mass Flow      +1.0000 SLPM
Volumetric Flow +1.0000 LPM
Abs Pressure    +160.00 PSIA

BACK  MAIN
```

Full scale ranges screen.

Manufacturer Information

MENU → ABOUT → About Manufacturer

About Manufacturer includes:

- Manufacturer name
- Web address
- Phone number
- Email address



```
ALICAT SCIENTIFIC
www.alicat.com
Ph 520-290-6060
info@alicat.com
```

About menu.

Process Control

Controllers

For a controller to regulate the flow or pressure, it needs to have a setpoint established. The setpoint is the amount of flow or the pressure that the controller attempts to achieve in a process.

Setpoint

SETPT or MENU → CONTROL → Setpt

The **setpoint selection screen** indicates the engineering units and maximum allowable setpoint (e.g., SLPM: +1.000 Max).

To establish a setpoint, enter the desired value and press **SET**, the instrument immediately begins to control the flow or pressure. A zero setpoint can be established by selecting **CLEAR** and then **SET**.

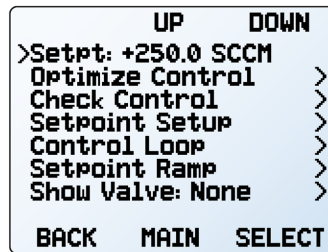

Control menu.

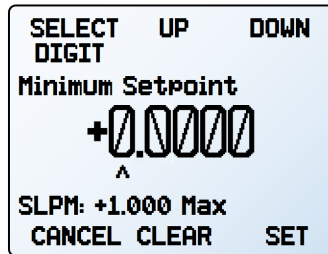

Setpoint screen.

Setpoint Options

The setpoint can be configured with a few options to better control your process based on your needs. Below are various setpoint options and functions.

Autotare and Zero Setpoint Options

MENU → CONTROL → Setpoint Setup → Zero Setpoint

A controller can automatically tare itself when it has a zero setpoint. Once the setpoint is given, the instrument waits a specified amount of time before taring. **Delay Before Tare** manages how much time the controller waits before taring. Make sure the delay provides enough time for the process to stop flow and settle.

! **Caution:** Autotare typically is not recommended for pressure controllers.

Control (Pressure controllers) When the setpoint is zero, this item determines if the control loop is actively controlling the pressure (**Active**), or if the valve is set to full closed, or full open for back pressure control (**Fixed**). For differential and bidirectional gauge pressure controllers, active is typically recommended; **Fixed** is typical for most other pressure control situations.

Ramp controls whether the instrument honors setpoint ramping down ([page 18](#)) or immediately goes to the zero setpoint. If set as **Honor ramp to 0**, the controller moves down to a zero setpoint at the specified ramp rate. If set as **Instantly to 0**, the controller immediately moves the process to zero when a zero setpoint is given.

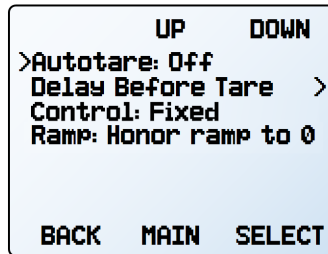

Zero setpoint (autotare) menu.

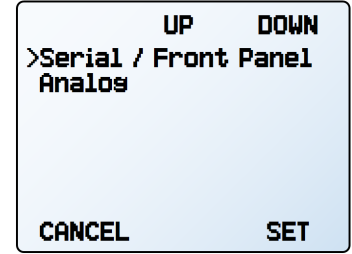

Setpoint source menu.

Setpoint Source

MENU → CONTROL → Setpoint Setup → Setpoint Source

Controllers with RS-232 or RS-485 communication accept setpoints from the front panel and serial commands ([page 35](#)). Alternatively, an analog source can be used instead.

- When the source is set to **Serial/Front Panel**, the controller accepts input from either the front panel or an RS-232/RS-485 connection. Neither source is a slave of the other, and the controller accepts the most recent command from either source.
- When the source is set to **Analog**, the instrument ignores serial setpoint commands and prevents setpoint input from the front panel.

Idle Connection Response

MENU → CONTROL → Setpoint Setup → On Comm Timeout

If the communication connection is timed out, the controller can either set a zero setpoint, or maintain the last setpoint given. The timeout time is infinite by default and can be manually defined ([page 30](#)).

Setpoint on Power-Up

By default, the controller remembers its last setpoint across power cycles, but a specific setpoint can be configured to be used on every power-up. It is possible to also configure the power-up setpoint to follow the ramp rate.

Power-Up Setpoint Value

MENU → CONTROL → Setpoint Setup → Power Up Setpoint → Value

By selecting **Fixed Setpoint** and entering a value, the instrument moves to the same setpoint every time after power-up, ignoring whatever the setpoint was before being powered off.

If the setpoint is digitally provided more than every few minutes, use a fixed setpoint on power-up to avoid wearing out non-volatile memory in the instrument.

Power-Up Setpoint with Ramping

MENU → CONTROL → Setpoint Setup → Power Up Setpoint → Ramp

This designates if the instrument follows the ramp rate or not after powering on. The instrument can either honor the ramp rate and ramp up (**Honor from 0**) or jump immediately to the power-up setpoint (**Jump from 0**).

For more information on ramping, see **Setpoint Ramping** ([page 18](#)). This functions the same as the power-up option in **Ramping Options**. Changing one overwrites the other.

Setpoint Limits

MENU → CONTROL → Setpoint Setup → Setpoint Limits

The **setpoint limits menu** configures upper and lower limits for selecting a setpoint. By default, the limits are the controller's measuring range, but more strict limits may be beneficial in certain applications.

Setpoint Ramping

MENU → CONTROL → Setpoint Ramp

Setpoint ramping regulates how quickly the controller reaches a new setpoint. It is often used to prevent bursts of pressure or flow from damaging delicate instruments at the start of a process.

To activate setpoint ramping, set a maximum ramp rate and configure when to enable the ramping function.

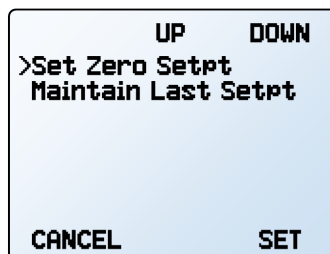

Communication timeout menu.

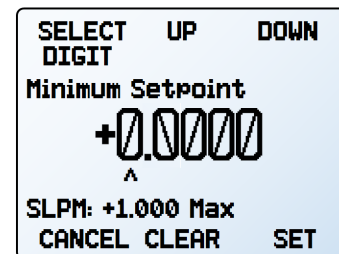

Setting a minimum setpoint.

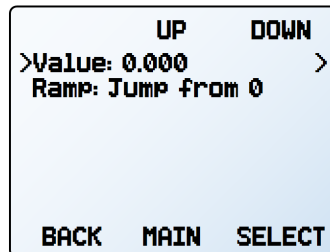

Power-up setpoint menu.

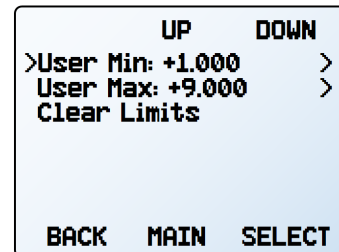

Setpoint limits menu.

Over a serial connection, the controller rejects requests of a setpoint outside the limit and an error is returned. When using an analog setpoint signal, setpoints that are outside of the setpoint limits are treated as if they were at the nearest limit. For example, if you request a setpoint via analog that is below the lower limit, the controller sets the setpoint at the lower limit.



Caution: Flow controllers that have non-zero lower setpoint limits cannot be set to stop flow until the lower limit has been cleared.



Note: When changing from one control loop variable to another, the controller remembers setpoint limits as percentages of full scale. For example, a 10-SLPM limit on a 20-SLPM controller (50% of full scale) will become a limit of 80 PSIA (50% of 160 PSIA) if the control loop is changed to absolute pressure.

Ramp Rate

- **Ramp** changes the maximum rate of change.
- **Units** displays the engineering units. Time units can be changed.
- **Set By Delta / Time** allows for more detailed control of the ramp rate including changing the value of the time period.

Ramping Options

Ramping options control when ramping occurs. This can be when the setpoint changes, when the instrument powers on, or when setting a zero setpoint.

- **Ramp Up** can toggle between on and off. When off, the ramp rate will not be honored when increasing flow or pressure to reach a given setpoint.
- **Ramp Down** can toggle between on and off. When off, the ramp rate will not be honored when decreasing flow or pressure to reach a given setpoint.
- **Power Up** toggles between **Allow Ramp** and **No Ramp**. If set to **No Ramp**, the instrument ignores the ramp rate just after powering on, otherwise it honors the ramp rate starting at a zero setpoint. This functions the same as **power-up setpoint with ramping** (page 18). Changing one overwrites the other.
- **0 Setpt** determines if the controller ramps when a zero setpoint is set. If this setting is set to **No Ramp** when given a zero setpoint, the controller immediately moves to the zero setpoint. Otherwise, the controller ramps at the selected rate.

```
          UP    DOWN
>Ramp: 100.0000 >
Units: SLPM / s >
Set by Delta / Time >
Ramp Up: On
Ramp Down: Off
Power Up: Allow Ramp
0 Setpt: No Ramp
BACK MAIN SELECT
```

Setpoint ramping menu.

```
SELECT UP    DOWN
DIGIT
Max Ramp Rate
  00.0000
  ^
SLPM / s
CANCEL CLEAR SET
```

Setting a maximum ramp rate.

```
          UP    DOWN
>Delta: +100.00 PSIA >
Time: 1.0000 s >
Time Units: s >
BACK MAIN SELECT
```

Configuring delta / time ramping.

✓ **Note:** Setpoint ramping can be used with flow or pressure setpoints, depending on the control loop selected. Ramping for pressure control limits how quickly pressure changes before reaching the setpoint. To limit flow rates directly while controlling pressure, see page 23.

Batch Dispensing Flow Controllers

BATCH or **MENU** → **CONTROL** → **Batch 1** or **Batch 2**

Batch dispensing flows a set volume of gas. Once that volume of gas flows through the controller, the valve closes and flow stops. You can repeat batches with a single button press.

To utilize batching, at least one totalizer must be enabled. The **BATCH** button can be found on the totalizer screen (page 14). When selecting from the **CONTROL** menu, **Batch 1** is for totalizer 1 and **Batch 2** is for totalizer 2. Only set one batch at a time to avoid premature stoppage in flow.

Start a Batch

1. Choose the total quantity to be dispensed in each batch. Press **SET** to accept the new batch size.
2. Once a batch size has been set, give the controller a setpoint (page 17). Flow begins as soon as you press **SET**.

✓ **Note:** Batch dispensing requires an active batch size and a non-zero setpoint. If your controller already has a non-zero setpoint, batching begins as soon as you press **SET** from the batch size screen.

While a batch is being dispensed, the remaining quantity to be dispensed is displayed below the total. When the batch is complete, **-DONE-** displays just above the **BATCH** button and flow stops automatically. The setpoint is not cleared and remains the same.

The batch size can be changed while a batch is in progress. If the new batch size is larger than the current totalized flow, then flow continues until the new value is reached. If the new batch size is smaller than the current totalized flow, then the flow stops immediately. Press **RESET** to start the new batch.

Repeat a Batch

- For an identical batch, press **RESET**. Flow begins immediately.
- For a new batch of a different size, press **BATCH**, and select the new batch size. If there is a non-zero setpoint, flow begins as soon as **SET** is pressed.

Pause or Cancel a Batch

To pause flow while a batch is in progress, change the setpoint to 0 by pressing **SETPT** → **CLEAR** → **SET** within the **totalizer** menu (and from other locations as well). This does not stop the timer. To resume, change the setpoint to a non-zero setpoint.

- To remove a batch setting, press **BATCH** → **CLEAR** → **SET** or **REMAIN** → **CLEAR** → **SET**. Deleting the batch does not affect the setpoint. Flow will continue at the setpoint rate.



Warning: Flow resumes immediately at the current setpoint when batch dispensing is turned off.



Note: The controller retains batch size across power cycles. The batch size must be manually cleared to remove it.

Valve Drive Percentage Display

MENU → CONTROL → Show Valve

The valve drive is represented as a percentage of the total possible voltage driven to the valve. While drive percentage does not directly correlate with percentage open, a drive percentage of 0% indicates the valve is not open.

Viewing the valve drive percentage can be helpful for troubleshooting. An increase in percentage over time likely indicates a blockage in the system where more voltage is required to drive the valve to attain the same amount of flow.

This information may be displayed on the **main display** and/or as part of transmitted serial data. There are four valve display options:

- **None:** No valve information is displayed.
- **Main Screen:** Only on the main display.
- **Digital Data:** Only in the serial data frame.
- **Screen and Digital:** Both on the main display and in the serial data frame.

Check Control Controllers

MENU → CONTROL → Check Control

Check Control is a convenient way to measure common flow control response variables. The data can be used to characterize instrument performance, to aid in adjusting the system or controller configuration, or to check whether optimization may be warranted.

To Run Check Control, enter a **GO TO** setpoint that is significantly different from the current setpoint, and enter a **TIME** period over which to collect data. After pressing **START**, the controller will move to the new setpoint, collecting data for the selected time period. The following values will be reported:

- **Overshoot:** The amount of process overshoot observed during the setpoint change.
- **Time Constant:** The amount of time required for the process to move 63.2% of the setpoint change after the process began to change.
- **Dead Time (time delay):** The time between when the setpoint was changed and when the process began to change.

GO TO	TIME
+10.000	2 s

AB PRS	+13.58 PSIA
M FLOW	+724.3 SCCM
CANCEL	

Check Control in progress.

GO TO	WARN	TIME
+10.000		2 s
Overshoot		+0.001 SCCM
Time Const		156 ms
Dead Time		1 ms
Bandwidth		1.8 Hz
BACK	MAIN	START

Check Control results.

- **Bandwidth:** The estimated frequency of the fastest sine wave setpoint that the instrument can reasonably follow. The instrument can be expected to reject most sinusoidal disturbances with a lower frequency.

The **WARN** button will be active to provide an explanation if the results may not be useful.

MENU → CONTROL → Optimize Control

Alicat instruments are set up at the factory to perform well over a range of expected conditions. If conditions change dramatically, or if the instrument needs to perform in a very specific way, then it may be beneficial to optimize the response.

The Autotune (Optimize Control) function automatically adjusts the control gains to improve response time for the current process and conditions. It is a much faster approach to manual tuning and does not require extensive knowledge of control parameters and methodology.

Autotuning is recommended:

- at installation, to match current process conditions
- when the process changes significantly, as when a dramatically different pressure is required, or when switching to a process gas with very different properties
- when the physical system changes significantly, as when adding a large restriction or volume
- when incorporating the instrument into a different process or lab experiment
- when an exact response is required, or when multiple instruments need to provide the same response
- when flow control has degraded due to process changes over time.

During autotuning, the instrument moves to a series of setpoints. For each setpoint change, the instrument determines system properties and optimizes control parameters. The absolute pressure and maximum flow will be reported throughout the process.

When complete, the instrument response is adjusted to the optimal settings, and the instrument reports the overshoot, dead time, time constant, and bandwidth of a typical response with the final settings ([page 20](#)).

For most instruments, autotuning is completed in 30–90 seconds. Ultra-low flow instruments (roughly 50 SCCM and below) may require longer; 0.5 SCCM instruments may take up to 15 minutes.

✓ Note: During autotuning, the instrument will move to various setpoints, some of which may exceed the current setpoint. If the maximum flow needs to be limited to protect the process, adjust the Max Flow setting (see Max Flow in the following section).

Optimization Recommendations

Autotuning will provide the best results when following these recommendations:

- Use process conditions that maximize the pressure delta across the valve(s). The instrument will perform best if it is operated at a pressure delta or common mode pressure equal to or less than the optimization value.
- Autotuning is more sensitive to fluctuations in the environment than normal closed loop control. Most

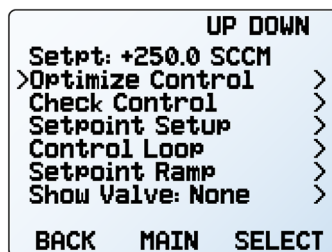

Optimize Control.

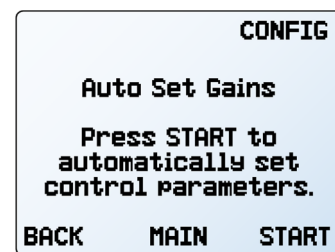

Press START to optimize control.

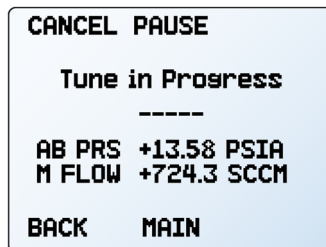

Optimize Control in progress.

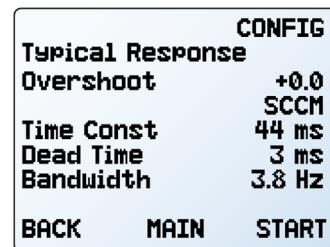

Optimization results.

fluctuations will result in control loop gains that are smaller than they might otherwise be, as it is difficult to separate the effects of the disturbance from the response of the system. Large fluctuations may preclude optimization. Ultra-low flow and other slowly responding instruments will be more sensitive to fluctuations.

- During autotuning, setpoint ramps are mostly honored. For autotuning, the instrument should be configured with the fastest setpoint ramp that will be used.
- Some valves will act significantly differently when they have not been opened for some time. Operating the valve prior to autotuning can minimize the potential impact.

Advanced Configuration Options

MENU → CONTROL → Optimize Control → Config

For most situations, the autotune function will determine the best response time using factory defaults. The function can, however, be further configured to support atypical process requirements or specific control goals.

Speed

The Speed setting determines how the function will address the tradeoff between speed and the ability to handle a range of process variability:

- **FAST:** the default option, which balances speed and versatility for most situations.
- **FASTEST:** maximizes response speed (i.e., minimizes the control loop response time). A small amount of overshoot is allowed.
- **VERSATILE:** accommodates a wider range of conditions, but with the tradeoff of slower response time. The system may not be able to respond to quickly changing conditions.

- **MOST VERSATILE:** accommodates an even wider range of conditions, but with slower response time.
- **GOAL:** enables advanced users to achieve a particular response profile or tune multiple instruments to an exact response. The function will attempt to achieve the response time goal. When the goal is impossible to meet (e.g., if it is set to 0), the nearest possible time constant will be used (which is equivalent to the FASTEST option).

Control Loop

The control loop manages which parameter is controlled and how the controller reacts to system changes.

The control response time can be optimized (autotuned) to maximize performance for the current range of process conditions. The Optimize Control function (see [page 20](#)) automatically adjusts control variables to achieve the best performance for the current process conditions.

If a particular response profile is required, or when multiple instruments need to provide the same response, manual tuning can be completed as described below.

Controlled Variable

MENU → CONTROL → Control Loop → Control

The controlled variable is the measurement the controller attempts to regulate to the given setpoint. Controllers can only control one variable at a time, but they still measure the other variables during that time. Below are the lists of possible variables each controller can control.

Mass Flow Controllers

Mass flow controllers can control mass flow, volumetric flow, pressure (absolute or gauge with barometer) or the valve drive.

Liquid Controllers

Liquid controllers can control volumetric flow, gauge pressure, and the valve drive.

Pressure Controllers

Pressure controllers can only control the pressure (absolute, gauge, or differential) and valve drive.



Note: When pressure is the selected variable, all controllers with upstream valves control the outlet pressure. Those with downstream valves control upstream back pressure, but these instruments must be configured for this type of control.



Warning: When changing the control loop, the PID settings may need adjusting for optimal stability and speed of response.

PD/PDF or PD²I Control Algorithms

MENU → CONTROL → Control Loop → Loop Type

Your controller uses an electronic closed loop to determine how to actuate its valve(s) in order to achieve the commanded setpoint. These settings are tuned at production for your specific operating conditions,

Max Flow

This setting limits the maximum flow during autotuning to protect delicate processes. In unusual circumstances the maximum flow may still be exceeded; however, the instrument will attempt to minimize the duration.

Loop Type

The autotuning function will use the best control loop based on the process. The AUTOMATIC option is, therefore, the default, and recommended, setting.

If required, either the PD²I or PDF closed loop algorithm can be specified for use during optimization (see [page 22](#)).

but changes sometimes require on-site adjustments to maintain optimal control performance. Fine-tuning your closed loop control may help correct issues with control stability, oscillation, or speed of response.

For most applications, PD/PDF is recommended. When controlling pressure with a dual valve controller (MCD or PCD instruments), PD²I is recommended.

Tuning the PD/PDF Control Algorithm

The controller's default control algorithm (PD) employs pseudo-derivative feedback (PDF) control, which uses two editable variables:

- The larger the **D** gain, the faster the controller corrects errors between the commanded setpoint and the measured process value. This is equivalent to the **P** variable in common PDF controllers.
- The larger the **P** gain, the faster the controller will correct for offsets based on the size of the errors and the amount of time they have occurred. This is equivalent to the **I** variable in common PDF controllers.



Note: The D and P variables in the PD/PDF control algorithm are more typically referred to as P and I, respectively, in PDF controllers.

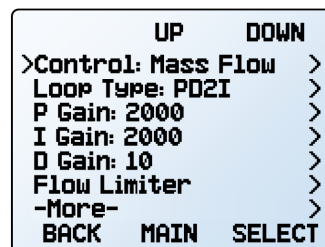

The control loop menu in PD²I control mode.

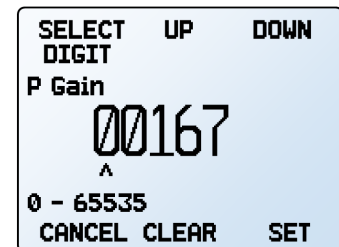

Setting a P Gain.

Tuning the PD²I Control Algorithm

PD²I usually provides a faster response in dual-valve flow and pressure controllers. This algorithm uses typical PI terms and adds a squared derivative term (D):

- The larger the **P** gain, the more aggressively the controller will correct errors between the commanded setpoint and the measured process value.
- The larger the **I** gain, the faster the controller will correct for offsets based on the size of the errors and the amount of time they have occurred.
- The larger the **D** gain, the faster the controller will predict needed future corrections based on the current rate of change in the system. This often results in slowing the system down to minimize overshoot and oscillations.

Troubleshooting Valve Performance with PID Tuning

The following issues may be resolved by adjusting the PID gain values for your controller.

Fast oscillation around the setpoint:

- **PD/PDF:** Reduce the **P** gain in decrements of 10%.
- **PD²I:** Increase the **P** gain in increments of 10%, and then adjust the **I** gain to fine-tune.

Overshot setpoint:

- **PD/PDF:** Reduce the **P** gain in decrements of 10%.
- **PD²I:** Increase the **P** gain in increments of 10%.

Delayed or unattained setpoint:

- **PD/PDF:** Increase the **P** gain in increments of 10%, and then decrease the **D** gain by small amounts to fine-tune.
- **PD²I:** Increase the **P** gain in increments of 10%, and then increase the **I** gain to fine-tune.

 Valve tuning can be complex. More detailed information is available at alicat.com/pid. Autotuning (In-device optimization) should typically be a first step before manual tuning. See [page 21](#).

Flow Limit while Controlling Pressure Flow Controllers

MENU → CONTROL → Control Loop → Flow Limiter
Limiting the flow rate while controlling pressure can help to avoid exceeding the measurable range of the instrument as well as prevent damage of sensitive instruments later in the process. To limit flow:

1. Choose either mass flow or volumetric flow to limit by selecting **TYPE**.
2. Set the maximum value of flow rate desired by selecting **MAX FLOW** and entering the maximum value in the engineering units displayed.

3. Set the **Limiter Gain** to 500 and adjust as needed. **Limiter Gain** determines how aggressively the proportional control function corrects the error when the flow rate exceeds the maximum flow setting. A higher value corrects more aggressively, but it is also more likely to oscillate near the flow limit.



Note: If both flow limiting and pressure setpoint ramping are active when controlling pressure, the more restrictive function regulates the controller's operation as it attempts to attain the setpoint.



Note: For bidirectional controllers, the flow limit will be symmetric. For example an MCD-20SLPM with a maximum set to 10 SLPM will be limited to between -10 SLPM and 10 SLPM.

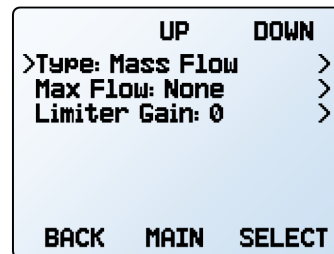

Flow limiter menu.

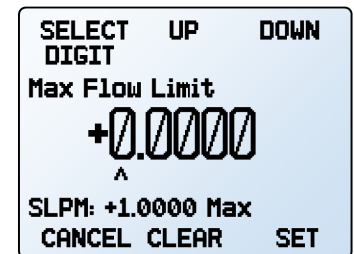

Setting a maximum flow limit.

Gas Adjust Mass Flow Controllers

MENU → CONTROL → Control Loop → Gas Adjust

Enabling Gas Adjust will change the control loop gains to keep the control response time more consistent as the gas is changed. Choose **On** to enable the feature, **Off** to disable, or **Until Set Gain** to use gas adjust to get more consistent performance.

Control Deadband for Pressure Control

MENU → CONTROL → Control Loop → Control Deadband

The control deadband is designed to minimize the amount of gas exhausted and improve stability. There is no active control within the deadband setting.

✓ Note: A control deadband cannot be set when the instrument is configured to control flow. If control is set to mass flow, the error "Only active when controlling pressure" displays instead of the deadband menu.

To turn on the control deadband, enter a non-zero value in CONTROL → Control Loop → Control Deadband → Deadband. The controller must first reach the setpoint for the deadband to engage. If the process variable drifts outside a deadband limit, active control resumes until the setpoint is reached again.

The controller can be set to either hold the current valve position or close the valve(s) in CONTROL → Control Loop → Control Deadband → When in Band. It is recommended to hold the current position on single valve controllers and close valves for dual valve controllers.

Example: With a setpoint of 30 PSIA, a deadband of ± 0.25 PSIA allows absolute pressure to vary between 29.75 and 30.25 PSIA.

! Caution: MC and PC series instruments do not have an exhaust valve to reduce pressure when pressure exceeds the deadband.

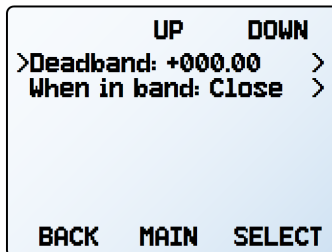

Deadband menu.

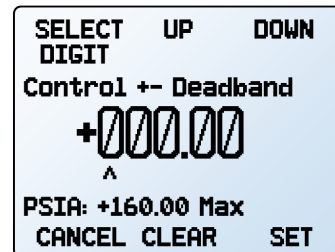

Choosing deadband size.

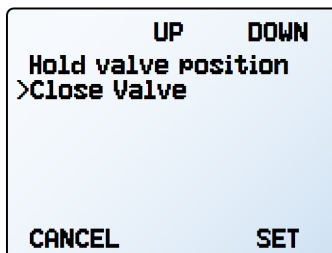

Choosing deadband options.

Instrument Setup

Gas Selection Mass Flow Instruments

Your mass flow instrument was physically calibrated at the factory using air. Gas Select™ allows you to reconfigure the instrument to flow a different gas without any need to send it back for a physical recalibration. The instrument can also be programmed to measure custom gas mixtures.

Gas Select™

MENU → SETUP → Active Gas

Within this menu, there are a variety of categories (such as **Standard**, **Chromatography** and **Welding**), as well as recent selections, and COMPOSER™ mixes (see next section). Each category lists a subset of available gases and pre-configured mixtures.

As soon as you press **SET** from the gas list, your instrument reconfigures its flow rate calculations to the newly selected gas's properties. There is no need to restart the instrument.

Your current gas selection appears just below the engineering units on the right side of the main display (see [page 11](#)).

Category and Gas List Controls

- **PAGE** advances the view to the next page of categories or gases.
- **SELECT** (in the category list) opens a list of gases in that category.
- **SET** (in the gas list) immediately loads the gas measurement properties and exits to the **setup** menu.

COMPOSER™ Gas Mixes

MENU → SETUP → Active Gas → COMPOSER Mixes

To remain accurate, your mass flow instrument needs to reference the viscosity of the gas you are flowing through it. The more closely you can define your actual gas composition, the more accurate your flow readings will be. COMPOSER™ is an included feature of Gas Select™ that lets you define new mixed gas compositions to reconfigure your flow controller freely.

Wilke's semi-empirical method is used to define a new gas mixture based on the molar (volumetric) ratios of the gases in the mixture. You can define these gas compositions to within 0.01% for each of up to five constituent gases in the mixture. Once you define and save a new COMPOSER™ gas mix, it becomes part of the Gas Select™ system and is accessible under the gas category **COMPOSER User Mixes**. You can store up to 20 COMPOSER™ gas mixes on your flow controller.

Select any existing mix and press **SET** to immediately configure your instrument to measure that gas mixture. To create new mixes, see the next section.

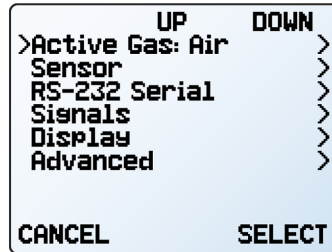

Setup menu.

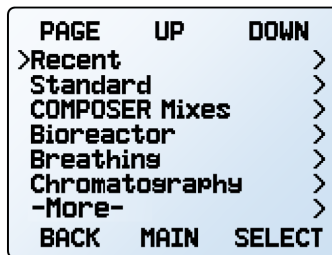

First page of the Gas Select™ category list.

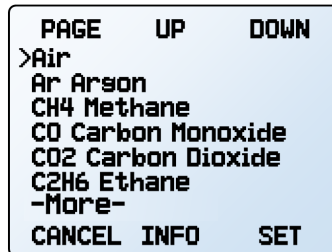

Gas Select™ standard gas list.

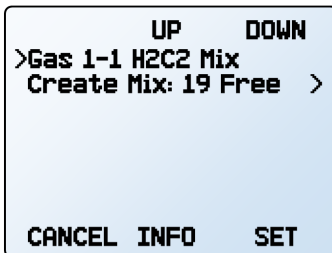

The COMPOSER™ menu with the new custom mix.



Note: The COMPOSER™ is instrument firmware, and does not physically mix gases. It only configures the instrument's calculations to report flow readings more accurately based on the constituent gases of your defined mixture.

Creating New Mixes in COMPOSER™

MENU → SETUP → Active Gas → COMPOSER Mixes → Create Mix

Give the Mix a Short and Long Name

UP/DOWN changes the character. Valid characters include A–Z, 0–9, punctuation (., –), and space. CANCEL exits to the mix settings menu. SET accepts the name.



Note: Using a space in the short name can cause the serial data frame to be read incorrectly by some programs.

Define the Mix

- **Add Gas to Mix** enters the Gas Select™ category listing. Once you find the correct gas, press SET. Enter the composition percentage and press SET.
- As gases are added, the total used percentage updates on the mix settings menu.
- Once gases have been added, COMPOSER™ automatically selects the percent balance then lets you adjust down.
- The sum percentage of gases must total 100% to select **Save Mix**. Selecting **BACK** will permanently discard the mix.
- Mixes that contain several gases push the menu to a second page; use the **PAGE** button to see the remaining list.

Viewing, Deleting, and Creating Similar Mixes

MENU → SETUP → Active Gas → COMPOSER Mixes → [Select mix] → INFO

The current configuration of any existing COMPOSER™ mix can be viewed by selecting **INFO** instead of **SET** in the mix list. It will show:

- Create a similar mix.
- Options to delete the mix.
- Short and long names.
- The gas number.
- The composition, which may extend to a second page. Pressing the **PAGE** button will move to the next page

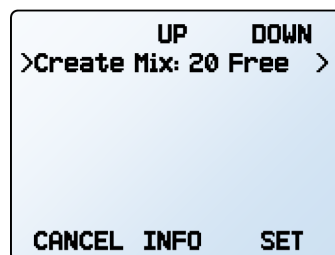

COMPOSER™ menu without existing mixes.

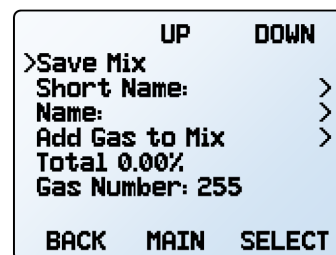

Mix settings menu.

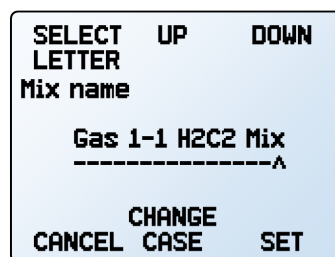

Defining a mixture's long name.

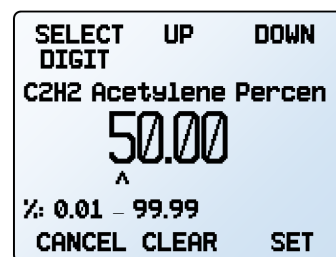

Setting the percentage of a constituent gas C₂H₂.

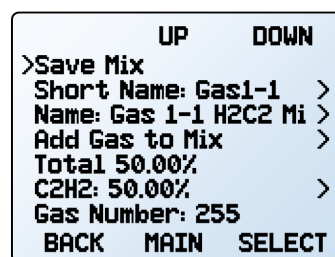

Results of adding of C₂H₂.

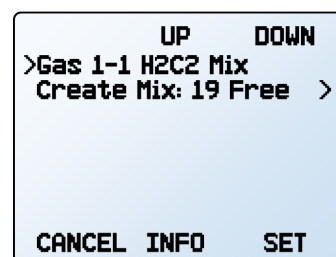

COMPOSER™ menu with the new custom mix.

Sensor Setup

MENU → SETUP → Sensor

Sensor setup controls how measurements are calculated and communicated by the instrument. These are factors like what engineering units are used and the standard or normal reference values for flow.

Engineering Units

MENU → SETUP → Sensor → Engineering Units

Changing engineering units alters both the display and the data frame. Choose the parameter whose unit you want to change, and then choose an engineering unit, confirming the change on the last screen.

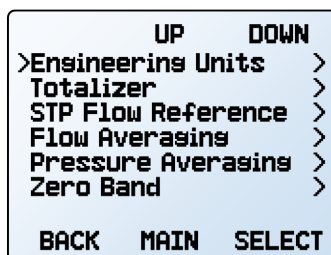

Sensor setup menu.

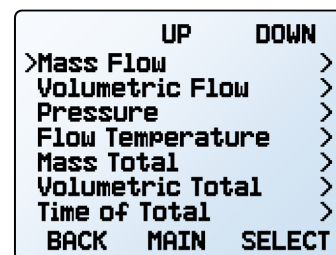

Engineering units menu.

Totalizer Options Flow Instruments

The totalizers measure the total flow over a given time. The current total values are shown in the Totalizer data screens ([page 14](#)).

Totalize Type

MENU → SETUP → Sensor → Totalizer → Totalizer 1 or Totalizer 2 → Totalize

Select whether to totalize **Mass Flow** or **Volumetric Flow**. Select **None** to disable the particular totalizer.

Restore Totalizer Value on Power-up

MENU → SETUP → Sensor → Totalizer → Power Up Restore

Turning this option on sets the instrument to retain the totalized values between power cycles. The instrument continues to count from its previous totalized amounts when power is restored.

If this setting is off, the totalizers reset to 0 when the instrument is powered off.

Batches Mass Flow and Liquid Controllers

MENU → SETUP → Sensor → Totalizer → Totalizer 1 or Totalizer 2 → Batch

Batching is only possible when a totalizer is enabled and works in concert with the setpoint. For more information on batching, see [page 19](#).

Totalizer Mode

MENU → SETUP → Sensor → Totalizer → Totalizer 1 or Totalizer 2 → Mode

All instruments have 2 options for calculating flow:

- **Positive Flow Only:** The totalizer only counts flow that passes left to right through the flow body of the instrument. If any negative flow (right to left) moves through the system, it is not counted.
- **Reset After No Flow:** When flow is completely stopped, the totalizer holds the current value of the measured flow until flow begins again. Once flow begins, the totalizer resets to zero.

Bidirectional dual valve controllers can have 2 further options for calculating flow:

- **Negative Flow Only:** The totalizer only counts negative flow (flow that passes right to left through the flow body of the instrument). Positive flow (left to right) is not counted.
- **Bidirectional:** The totalizer adds flow that moves positively through the system and subtracts flow that moves negatively.

Totalizer Limit and Format

MENU → SETUP → Sensor → Totalizer → Totalizer 1 or Totalizer 2 → Limit and Format

The totalizer can report up to a maximum of 10 digits. Seven digits is often used in systems that utilize single-precision floating point numbers; more digits requires the use of double-precision floating point values or specialized numerical handling.

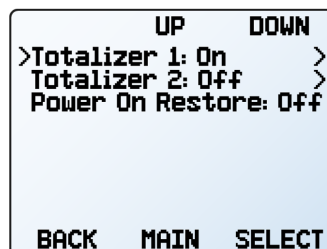

Totalizer On/Off screen.

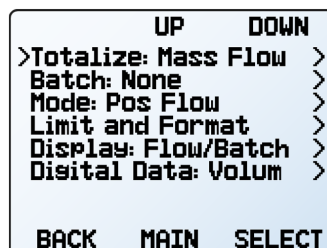

Totalize Type options.

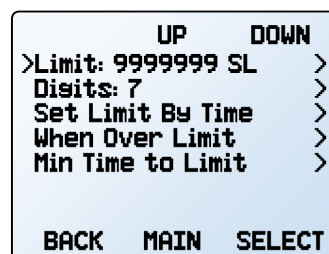

Totalizer Limit and Format screen.

If the number of digits has been set to less than 10, there is a trade off between the available resolution and how much fluid can be accumulated before the maximum limit is reached. Moving the decimal point so there are more digits after the decimal point allows more resolution in the reported volume/mass, but the maximum limit will be smaller, and therefore will be reached sooner.

The instrument allows the maximum limit to be set multiple ways. If there is a known limit that the volume/mass will never exceed, this can be used to set the maximum limit directly to maximize the available resolution. The maximum volume/mass is often not known, but a general time frame may be known. This general time interval can also be used to set the maximum limit to ensure that the volume/mass can be tracked without reaching the limit.

The totalizers generally can be configured to guarantee that the limit will not be reached for at least 10 minutes of full scale flow (maximizing resolution) to at least 100 years. However, unusual combinations of total units and flow range may limit the available range.

The combination of total units and flow range also impacts how many digits are available after the decimal place. How the totalizer reacts is based on the **Totalizer Limit** settings.

Totalizer Limit

There are 4 options for how the totalizer reacts when it reaches its limit:

- **Set to Zero:** Totalizer resets and continues counting from zero once the maximum count is reached. No error status is displayed.
- **Zero and Set OVR:** Totalizer resets to zero and continues once the maximum count is reached. The **OVR** status message is active to indicate maximum count has been reached (page 11).
- **Hold and Set OVR:** Totalizer stops counting at max count until it is reset manually. Displays **OVR** status message to indicate maximum count has been reached (page 11).
- **Hold:** Totalizer stops counting at max count until it is reset manually. No error is displayed.

The totalizer also calculates the minimum time the totalizer will run before it reaches the totalizer limit. Once all the settings have been confirmed, selecting **Min Time to Limit** shows how long the totalizer can run at full flow before the limit is reached. Increasing the number of digits and moving the decimal to the right will increase this time.

The elapsed time counter is format dependent. Many formats will not reach the max time for over 100 years.

Totalizer Display

MENU → SETUP → Sensor → Totalizer → Totalizer 1 or Totalizer 2 → Display

Totalizers have 3 options to display on the main screen.

- **Flow and Batch (Default):** Provides basic flow information, along with setpoint and batch configuration.
- **Detailed Flow:** Similar to Flow and Batch but without batching. Provides information focused on flow rates, accumulated total, and average flow.
- **Multi-variable:** Screen that resembles the main display (page 11).

Totalizer Digital Data

MENU → SETUP → Sensor → Totalizer → Totalizer 1 or Totalizer 2 → Digital Data

This setting enables the instrument to report the totalizer value in the data frame (page 35). There are two options available:

- **None:** The totalizer value is not included in the data frame.
- **Volume:** The totalizer reports the current value of the totalized volume in the data frame.

Totalizer while Controlling Pressure

While using a mass flow or liquid controller to control pressure, the flow rate may exceed the maximum measurable flow (128% of full scale) with an abrupt pressure change. In this case, the totalized value flashes and the **TMF** error appears. The **TMF** error indicates that the totalizer missed flow data. Reset the totalizer to clear the error message.

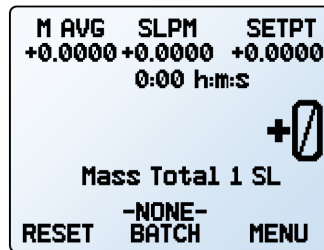

Totalizer Flow and Batch view.

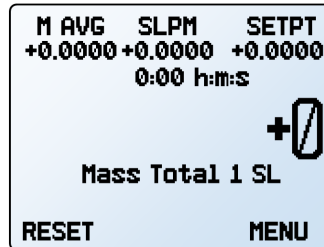

Totalizer Detailed Flow view.

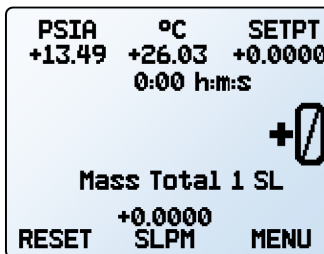

Totalizer Multivariable view.

Setting an upper flow limit (page 23) within the readable range prevents this error, but the flow limit would be given preference over reaching the pressure setpoint.



Warning: In certain situations, it is possible to exceed the batch size when controlling pressure. As an example, if the feed pressure is too low to achieve the flow setpoint and then pressure suddenly increases, the batch size may exceed its limit before the valve reacts to the sudden burst of pressure.

STP/NTP Reference Values Mass Flow Instruments

MENU → SETUP → Sensor → STP Flow Ref or NTP Flow Ref

A mass flow instrument references a given temperature and pressure combination to calculate flow. Standardized flow units begin with "S" and normalized mass flow units begin with "N." Depending on the engineering units selected, either STP or NTP will be editable from this menu. For example, if SLPM (Standard Liters Per Minute) is selected, STP is editable. If NLPM (Normal Liters Per Minute) is selected, NTP is editable.

Reference options:

- **Stan T:** Standard Temperature
- **Stan P:** Standard Pressure
- **Norm T:** Normal Temperature
- **Norm P:** Normal Pressure
- **Ref temp units** changes the temperature units used for STP and NTP values
- **Ref pressure units** changes the pressure units used for STP and NTP values

Unless otherwise requested, your flow controller ships with a default STP of 25°C and 1 atm, and an NTP of 0°C and 1 atm.

! **Caution:** Changes to STP or NTP references alters your mass flow readings.

Flow and Pressure Averaging

MENU → SETUP → Sensor → Flow Averaging

MENU → SETUP → Sensor → Pressure Averaging

Averaging the flow over a longer time may be useful in smoothing fluctuating readings. This menu changes the time constants of the geometric running averages for flow and pressure. Values are the time constant (in milliseconds) of the averaged values. Higher numbers generate a greater smoothing effect. The instrument is capable of a maximum 255 ms.

Serial Communication Configurations

MENU → SETUP → RS-232 Serial or RS-485 Serial

You can operate your instrument via its data connection for easy streaming and logging of all data. Before connecting the instrument to a computer, ensure that it is ready to communicate by checking the options in this menu.

For more on how to issue commands from over serial communications, see [page 31](#).

Unit ID

MENU → SETUP → RS-232 Serial or RS-485 Serial → Unit ID

The unit ID is the identifier that a computer uses to distinguish your instrument from other, similar instruments when it is connected to a network. Using the unit ID letters A-Z, you can connect up to 26 instruments to a computer at the same time via a single COM port. This is called **polling mode** ([page 34](#)). Unit ID changes take effect when you select SET.

If you select "@" as the Unit ID, the instrument enters **streaming mode** ([page 34](#)).

Stream

MENU → SETUP → RS-232 Serial or RS-485 Serial → Stream

This option sets the interval between the beginning of each data frame transmission.

Enter a value between 0 and 999999999 ms. If the interval is shorter than a data frame can be completely transmitted, the next data frame will begin transmitting immediately after the previous one completes.

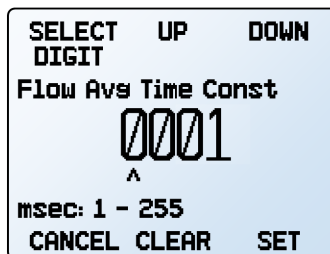

Adjusting the flow averaging time constant.

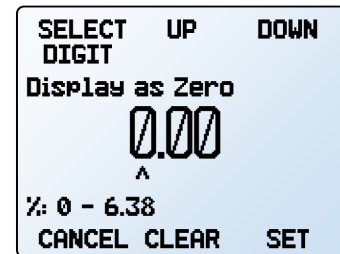

Configuring the zero band.

Zero Band

MENU → SETUP → Sensor → Zero Band

The zero band threshold is an amount of flow or pressure under which measurements are displayed and reported as 0. The maximum zero band is 6.38% of full scale. For example, a 20 SLPM controller with a zero band value of 0.25% displays as 0 SLPM for all readings below 0.05 SLPM. This function also applies to gauge pressure readings when using the optional barometer.

MODBUS RTU Address

MENU → SETUP → RS-232 Serial or RS-485 Serial → Modbus Address

The MODBUS RTU address is the identifier that a computer or programmable logic computer (PLC) uses to distinguish your instrument from others when it is connected to a MODBUS network. Values of 1-247 are available for use.

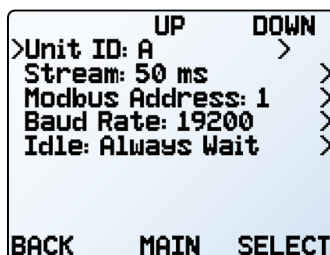

Serial communication menu.

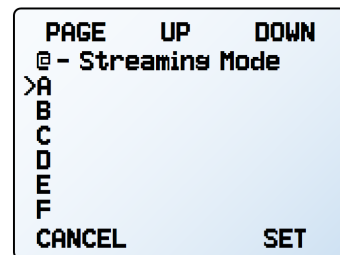

Choosing a unit ID, or streaming.

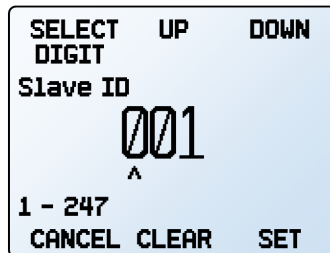

Modbus address menu.

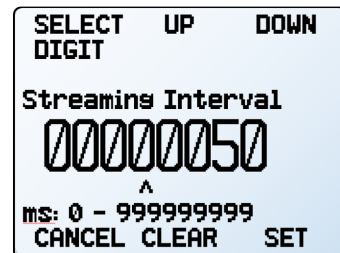

Serial communication Streaming interval.

Baud Rate

SETUP → RS-232 Serial or RS-485 Serial → Baud Rate

Baud rate is the speed at which digital instruments transfer information over a serial connection. The instrument has a default baud rate of 19200 baud (bits per second). If your computer or software uses a different baud rate, you must change the instrument's baud rate in the **BAUD** menu to ensure they match. Alternatively, you can change your computer's baud rate (use Windows® Device Manager for most applications). Baud rate changes take effect once you press **SET**, but you may need to restart any software for it to recognize the change.

Manage Setpoint when Connection is Idle

Controllers

MENU → SETUP → RS-232 Serial
or RS-485 Serial → Idle:

If a text serial or MODBUS RTU connection is idle (no valid request received) for a specified amount of time, the controller can either move to a zero setpoint, or maintain the previous setpoint. The idle time will be infinite by default (**Idle: Always Wait**) and can be set up to 99999.9 seconds (1 day, 3 hours, 46 minutes, 39.9 seconds).

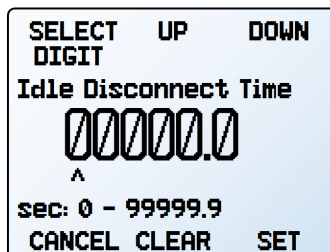

Setting an idle disconnect time.

Signals

MENU → SETUP → Signals

These options define the value tracked by the analog outputs. Select the primary (**Out 1**) or secondary (**Out 2**) analog output, then choose the value to track:

- **Min Value** fixes the output at the minimum value the output can produce. For example, the output would produce a constant 4 mA for a 4–20 mA output.
- **Max Value** fixes the output at the maximum value the output can produce.
- **Other values** will track readings measured by the instrument and will vary depending on the instrument.

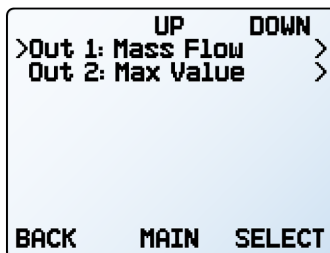

Signals setup menu.

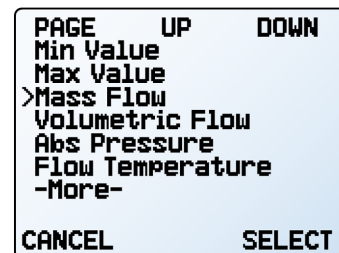

Signal parameter values.

Display Setup

The options in the **display setup** menu adjust the contrast/brightness of the display and enable screen rotation.

Data Screens

MENU → SETUP → Display → Data Screens

The data screens menu provides options for the various screens of the instrument. For more information on the contents of the screens and their functions, see the **Data Screens** section ([page 14](#)).

Main Screen

MENU → SETUP → Display → Data Screens → Main:

To select which screen displays when **MAIN** is pressed, select from one of the options in this menu. Only screens that have been enabled are available for selection. If the live screen is not selected, it can be reached by pressing **NEXT** on the main screen.

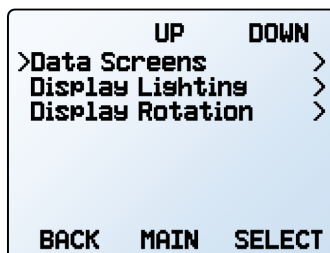

Display setup menu.

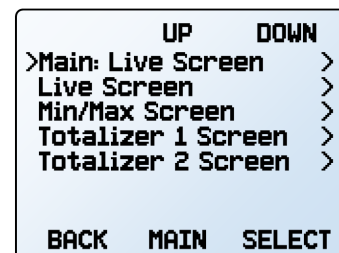

Data screens menu.

Live Screen Options

MENU → SETUP → Display → Data Screens → Live Screen

- **Any Key Press** changes what happens when any of the parameter buttons on the **main display** ([page 11](#)) are pressed (pressure or temperature, for example). By default, these buttons highlight their measurement in the center of the display. If

this option is set to **Show Actions Menu**, an option to change that parameter's engineering units is shown, as well as an option to highlight the parameter.

- **Show Valve Drive** shows or hides the valve's drive percentage on controllers. See [page 20](#).
- **Top Left Key Value** configures which type of pressure (barometric, gauge, absolute) is displayed when an optional barometer is installed in the instrument.

Enable Min/Max Screen

MENU → SETUP → Display → Data Screens → Min/Max Screen

- **Show** enables the min/max screen.
- **Hide** disables the min/max screen.

Totalizer 1 and Totalizer 2 Screen Options

MENU → SETUP → Display → Data Screens

→ Totalizer 1 or Totalizer 2

The totalizer screen options behave in the same manner as outlined in the **Totalizer Display** section ([page 14](#)). Performing changes in this menu performs the same change in the totalizer display menu. The opposite is true as well, where changes in the totalizer display menu are reflected in this menu.

- **Flow and Batch (Default)**: Provides basic flow information, along with setpoint and batch configuration
- **Detailed Flow**: Similar to Flow and Batch but without batching. Provides information focused on flow rates, accumulated total, and average flow.

Advanced Setup

MENU → SETUP → Advanced

The **advanced setup menu** contains useful settings and information for troubleshooting with customer support.

Factory Restore

MENU → SETUP → Advanced → Factory Restore

If something is not acting as expected, please contact an applications engineer prior to doing a **Factory Restore** to help confirm a restore is necessary. This immediately prompts a confirmation screen. Upon confirmation, all settings and registers are returned to their default settings.

 **Caution:** Performing a factory restore removes any and all 3rd party calibrations.

Register Status

MENU → SETUP → Advanced → Register Status

The **Register Status** screen displays live values for the internal instrument registers. Many of these values can help an applications engineer diagnose operational issues during technical support. Some register values clearly

- **Multi-variable**: Screen that resembles the live screen ([page 11](#)).

Screen Lighting

MENU → SETUP → Display → Display Lighting

The options and wording in the **screen lighting menu** varies between monochrome and color displays.

- On monochrome displays, press **LESS CONTRAST** or **MORE CONTRAST** to adjust the contrast levels. **POWER UP Lit** or **Dark** toggles whether the backlight of the unit will be on when the instrument powers on.
- On color displays, press **LESS BRIGHT** or **BRIGHTER** to adjust the brightness level.

Display Rotation

MENU → SETUP → Display → Display Rotation

The instrument has the option of inverting (flipping) the screen upside-down, as configured in this menu. Use this if the instrument is installed upside down.

distinguish between hardware and operational problems, which speeds up the troubleshooting process.

Edit Register and Instrument Properties

MENU → SETUP → Advanced → Edit Register

MENU → SETUP → Advanced → Device Properties

Editing registers and instrument properties allows technical support to fine tune instrument functions. These functions are best left alone, and used only when working with Alicat to diagnose or correct an issue. If your instrument is not functioning as expected, please contact Alicat support for assistance ([page 2](#)).

 **Caution:** Editing these settings may cause the instrument to become inoperable. Do not modify them without working with an applications engineer.

Digital Control

Alicat instruments can be operated using Alicat FlowVision™ 2.0 software, ASCII serial commands, or MODBUS RTU protocol.

- **FlowVision 2.0:** [page 32](#)
- **Serial ASCII Communication:** [page 33](#)
- **MODBUS RTU:** [page 39](#)

FlowVision 2.0

FlowVision™ 2.0 is Windows-based software that enables easy collection and analysis of data from Alicat controllers and meters. FlowVision controls the instrument, runs scripts, and logs and charts data. It also provides easy access to select the gas, amount of flow averaging, and PID loop tuning to adjust response speed and stability for some applications.

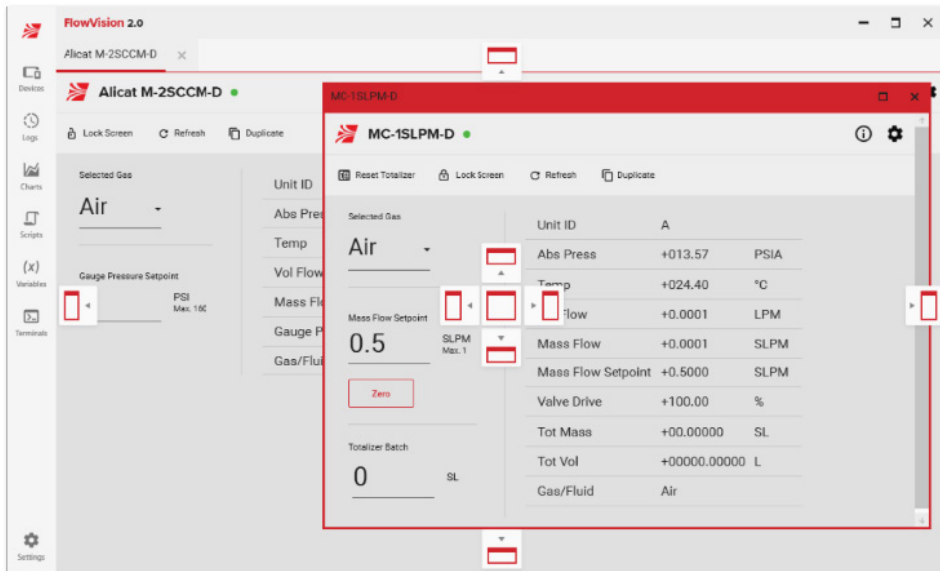

Establishing Communication

To connect your instrument to FlowVision 2.0:

1. Download FlowVision 2.0 from alicat.com/flowvision and install.
2. With the instrument turned on and connected to the computer, start FlowVision 2.0.
3. Click Devices in the top left corner.
4. Click the green plus sign to add your instrument.
5. Select Wired for the connection type.
6. Specify the connection settings. By default, the Device ID is A, and the Baud Rate is 19200. The Port is dependent on which COM port the instrument is connected to.
7. Specify a Name if desired. FlowVision 2.0 generates a name if the field is blank.
8. Click Add to complete the process.

Please see the FlowVision 2.0 manual at alicat.com/flowvision for detailed instructions on operating your instrument through FlowVision.

Serial ASCII Communication

Alicat's Serial Terminal is a pre-configured program for serial communication via the instrument's serial connector. Download Serial Terminal for free at alicat.com/drivers. Terminal is also available within FlowVision 2.0 ([page 32](#)).

The section below outlines several common commands. Many more commands are available. For more detailed information please see the Serial Primer manual at alicat.com/manuals.

Establishing Communication

After connecting your instrument using a communications cable, you will need to establish serial communications through a real or virtual COM port on your computer or programmable logic computer (PLC).

- If you have connected your instrument to a serial port, note its COM port number, which can be found in the Windows® Device Manager program.
- If you have used a USB cable to connect your instrument to your computer, then in most cases it will recognize your USB as a virtual COM port. If it does not, download the appropriate USB driver at alicat.com/drivers and note the COM port number as found in Windows® Device Manager.

The controller has the following default settings:

- **Baud:** 19200 (by default; others can be used if the computer, software, and the controller are all set to the same rate)
- **Data bits:** 8
- **Parity:** none
- **Stop bits:** 1
- **Flow control:** none



Note: In the following, ↵ indicates an ASCII carriage return (decimal 13, hexadecimal D). For many instruments, this is the same as hitting the Enter key. Serial commands are not case-sensitive.

Alicat's Serial Terminal Application

Alicat's Serial Terminal is a pre-configured program for serial communications. It functions much like the older Windows® HyperTerminal with plain text in a command-line format.

Download Serial Terminal for free at alicat.com/drivers. Once downloaded, simply run SerialTerminal.exe. Enter the COM port number to which your instrument is connected and the baud rate of the instrument. The default baud rate is 19200, but this is adjustable in the **RS-232 Serial1** menu on your instrument ([page 30](#)).

Unit ID

Each instrument has a unique, single-letter ID using the standard 26-letter English alphabet (e.g., A, B, C, etc.). The default ID is "A". If more than one instrument on a COM port has the same ID, data and commands become corrupted and do not report or execute properly. When connecting multiple instruments on the same COM port, connect one instrument at a time. Provide a unit ID command for each instrument before connecting the next instrument.

To give the most recently connected instrument an unused ID:

Change the unit id command: `unit_id@ desired_id`

Taring the Instrument

Taring gives the instrument a zero reference for flow and pressure measurements, ensuring that the instrument provides its most accurate measurements. It is recommended to tare the instrument:

- after installation
- when changing the instrument's orientation
- if the instrument is hit with any significant impact
- after any significant changes to the temperature or pressure.

If autotare is enabled on a controller ([page 17](#)), this can be accomplished by providing a setpoint of 0 for at least 2 seconds.

Manual taring can be accomplished through two separate commands for flow and pressure. Taring flow sets the zero flow reading and must be done when no flow is passing through the instrument:

Tare the flow: `unit_idV↵`

Example: `AV↵` (sets flow reading to zero)

Taring a gauge or differential pressure sensor must be performed when the instrument is open to atmosphere.

Tare the pressure: `unit_idP↵`

Example: `AP↵`

For instruments equipped with a barometer, the second tare aligns the internal absolute pressure sensor with the current barometer reading and must be done with the instrument open to atmosphere:

Tare the absolute pressure: `unit_idPC↵`

Example: `APC↵`

It is possible for the sensor zero to shift with changes in temperature and pressure. This is most often indicated by the instrument not reading zero when at a 0 setpoint. The autotare algorithm will automatically zero the instrument any time a 0 setpoint is given, after a small delay (flow range dependent). For most ranges, the tare will execute in 2 seconds or less after receiving a 0 setpoint. See the Serial Primer at alicat.com/manuals for more on autotare.

Collecting Data

Live data can be collected in either Polling or Streaming mode.



Note: Before collecting data, be sure to tare your instrument. If autotare is enabled on a controller, this can be accomplished by providing a setpoint of 0 and waiting for the flow readings to reach zero.

Polling Mode

Your instrument was shipped in polling mode with a unit ID of **A**, unless requested otherwise. Polling the instrument returns a single line of data each time you request it. To poll your instrument, enter its unit ID.

Poll the instrument: `unit_id↵`

Example: `A↵` (polls unit A)

You can change the unit ID of a polling instrument by typing:

Change the unit ID: `current_unit_id@ desired_unit_id↵`

Example: `A@ B↵` (changes unit A to unit B)

This can also be achieved via the instrument's front panel menu ([page 29](#)). Valid unit IDs are letters A-Z, and up to 26 instruments may be connected at any one time to a single COM port, as long as each unit ID is unique.

Streaming Mode

In streaming mode, your instrument automatically sends a line of live data at regular intervals. Only one unit on a given COM port may be in streaming mode at a time. To put your instrument into streaming mode:

Begin streaming: `unit_id@ @↵`

Example: `A@ @↵` (puts instrument A into streaming mode)

This is equivalent to changing the unit ID to "@". To take the instrument out of streaming mode, assign it a unit ID by typing:

Stop streaming: `@@ desired_unit_id↵`

Example: `@@ a↵` (stops streaming and assigns unit ID of A)

When sending a command to a instrument in streaming mode, the flow of data will not stop while the user is typing. This may make the commands you type unreadable. If the instrument does not receive a valid command, it will ignore it. If in doubt, press Backspace a number of times, then `↵`, and start again.

The default streaming interval is 50 ms. This can be increased by using the set streaming interval command:

Set the streaming interval: `unit_idNCS number_of_ms↵`

Example: `ANCS 500↵` (streams new data every 500 ms)

Data Format

Collect live data by typing the `unit_id` command or by setting your instrument to streaming. Each line of data for live measurements appear in the format below. The measurements present are dictated by the type of instrument. Meters and gauges do not show a setpoint.

Mass Flow Controller

A	+15.542	+24.57	+16.667	+15.444	+15.444	22741.4	N2
ID	Abs. Pressure	Temperature	Vol. Flow	Mass Flow	Setpoint	Totalizer	Gas

Gauge Pressure Controller

A	+20.00	+20.00
ID	Gauge Pressure	Setpoint

Liquid Controller

A	14.70	+24.57	+02.004	+02.004
ID	Gauge Pressure	Temperature	Vol. Flow	Setpoint

Single spaces separate each parameter, and each value is displayed in the chosen instrument engineering units (page 26). You can query the engineering units of the serial data frame by typing:

Query live data info:

`unit_id??D*`

Example: `A??D*` (returns the data frame descriptions)

Additional columns, including status codes (page 11), may be present as the rightmost column. The unit ID appears in the data frame only when the instrument is in polling mode.

Setpoint Controllers

Before attempting to send a setpoint to your controller serially, confirm that its setpoint source is set to **Serial/Front Panel** (page 17).

When sending a new setpoint, the data frame returns the new setpoint value when it has been accepted as a valid setpoint. The controller reads the requested setpoint using the current engineering units that have been selected (page 26).

Move to a new setpoint:

`unit_id Sfloating_point_number_setpoint`

Example: `AS 15.44` (setpoint of +15.44 SLPM)

When using a bidirectional controller, negative setpoints are sent by adding a hyphen for the minus sign (-):

Example: `AS -15.44` (setpoint of -15.44 SLPM)

Check Control Flow and Pressure Controllers

The instrument will change the setpoint from the current value to the provided setpoint value, and process data will be collected for the provided period of time. Control related statistics are calculated and returned.

Run Check Control:

`unit_id LCRC goto_setpoint collection_time`

Example: `A LCRC 10.00 2` (move to setpoint of 10 SLPM, record for 2 sec)

`goto_setpoint` is the setpoint to move to during this test. It must be different from the current setpoint. If the setpoint source is analog, `goto_setpoint` will override that setpoint for the duration of data collection. The setpoint will return to the normally configured setpoint as soon as the data collection is complete.

`collection_time` is the duration to collect process data after changing the setpoint. The default value is 2 seconds. Non-Whisper flow controllers with a smaller full scale range may require up to 10 or 20 seconds of data collection.

When controlling pressure, the collection time will depend on the fill or bleed time for the requested setpoint change. It should be about three times longer than the expected fill/bleed time. Choosing a `goto_setpoint` closer to the normal setpoint will reduce the fill/bleed time.

Following the operation, the instrument will return:

`unit_id termination notes overshoot delaymsec timeconstantMsec risetimemsec bandwidthhhz`

where

`termination` is 0 for normal operation; 1 if the operation was aborted manually; or, 2 if aborted due to oscillation.

`notes` are observations on reliability of the results. Values in the following table may be added for a single collection.

Value	Notes
0	The process data showed typical patterns.
+1	The data collection time was not long enough to ensure reliable results.
+2	The process variable oscillated significantly. Control was not stable and the calculated results are not reliable.
+4	The process variable moved a small amount compared to the noise observed in the system, so the calculated results may not be reliable. This most commonly happens when the setpoint change is too small or when the process variable oscillated in a manner that was not caught by the oscillation detection algorithm.
+8	A valve that has been closed was opened during data collection. The results are computed correctly, but the performance will be significantly different than if the valve was already open at the start of data collection.
+16	During data collection, the valve was opened as far as it could go. The results are computed correctly, but the performance is likely limited by the size of the valve, not the control loop configuration.

`overshoot`: The maximum overshoot observed during the trial, a floating point number in the units of the setpoint.

`delaymsec`: The system delay seen during the control trial, a floating point number in milliseconds. This is appropriate for use in a first-order-plus-dead-time (FOPDT) model of the instrument.

`timeconstantmsec`: The closed loop time constant (T63) seen during the trial. It is a floating point number in milliseconds and is appropriate for use in an FOPDT model of the instrument.

`risetimemsec`: The time required for the closed loop response to go between 10% of the step and 90% of the step during the trial. This is a floating point number in milliseconds.

`bandwidthhhz`: The estimated frequency, in Hz, of the fastest sine wave setpoint that the instrument can reasonably follow. The instrument can be expected to reject most sinusoidal disturbances with a lower frequency.

Optimize Control (Autotune) Flow Controllers

The Optimize Control function automatically adjusts the control gains to improve response time for the current process and conditions. Optimization is recommended:

- at installation, to match current process conditions
- when the process changes significantly, as when a dramatically different pressure is required, or when switching to a process gas with very different properties
- when the physical system changes significantly, as when adding a large restriction or volume
- when incorporating the instrument into a different process or lab experiment
- when an exact response is required, or when multiple instruments need to provide the same response
- when flow control has degraded due to process changes over time.

During autotuning, the instrument will open the valve to varying degrees to estimate system behavior and determine control loop gains to match. This process typically requires 10–90 seconds to complete. Some instruments (e.g., 0.5 SCCM instruments) may require up to 15 minutes. When complete, the instrument response is adjusted to the optimal settings, and various process parameters are reported.

Optimize Flow: `unit_id LCTCS speed_mode goal_time algorithm`

Example: `A LCTCS 3` (optimize using the FAST speed mode)

where

`speed_mode` determines how the function will address the tradeoff between speed and the ability to handle a range of process variability.

Value	Mode	Notes
0	Goal	Use the <code>goal_time</code> parameter as the target speed. This option allows advanced users to target a particular response time or to match the response of multiple instruments.
1	Most versatile	Accommodates the widest range of conditions, but with the slowest response time. The system may not be able to respond to quickly changing conditions.
2	Versatile	Accommodates a range of conditions, but with the tradeoff of slower response time.
3	Fast	The default option, which balances speed and versatility for most situations.
4	Fastest	Maximizes response speed (i.e., minimizes the control loop response time). A small amount of overshoot is allowed.

`goal_time` is the desired control response time constant, when the `speed_mode` is 0 (i.e., Goal mode). It is a nonnegative integer in milliseconds. If the requested time constant is smaller than the system can accommodate, optimization will find the gains with the shortest time constant; therefore, using 0 will result in the fastest possible time constant (same as `speedMode = 4`).

`algorithm` is the closed loop control algorithm to apply during optimization. Typically this value is 0, allowing the optimization function to use the most appropriate algorithm. For advanced users with particular requirements, the value can be set to 1 for the PDF control algorithm or 2 for the PD²I algorithm.

Max Flow

During optimization, the setpoint will be moved several times, potentially to values larger than the current setpoint. To protect delicate processes, a maximum flow can be established.

Set the Max Flow: `unit_id LCTCF max_flow`

Example: `A LCTCF 0` (optimize with max flow equaling the full scale range)

`max_flow` is the maximum flow allowed during optimization, a floating point number in the units of the current setpoint. Use 0 to allow the full scale flow range. This value must be at least 20% of the full scale flow of the instrument. During optimization this value may be exceeded, but the instrument will attempt to minimize the time this limit is exceeded.

Optimization Recommendations

Autotuning will provide the best results when following these recommendations:

- Use process conditions that maximize the pressure delta across the valve(s). The instrument will perform best if it is operated at a pressure delta or common mode pressure equal to or less than the optimization value.
- Autotuning is more sensitive to fluctuations in the environment than normal closed loop control. Most fluctuations will result in control loop gains that are smaller than they might otherwise be, as it is difficult to separate the effects of the disturbance from the response of the system. Large fluctuations may preclude optimization. Ultra-low flow and other slowly responding instruments will be more sensitive to fluctuations.
- During autotuning, setpoint ramps are mostly honored. For autotuning, the instrument should be configured with the fastest setpoint ramp that will be used.
- Some valves will act significantly differently when they have not been opened for some time. Operating the valve prior to autotuning can minimize the potential impact.

Gas Select™ and COMPOSER™ Mass Flow Instruments

To reconfigure your flow instruments to flow a different gas, look up its gas number ([page 47](#)). For more information on how Gas Select™ and COMPOSER™ work, see [page 25](#).

Choose a gas: `unit_idG gas_number`

Example 1: `AG8` (reconfigures to flow nitrogen)

Example 2: `AG206` (reconfigures to flow P-10)

User mixes are selected in the same way. All COMPOSER™ gas mixes have a mix number between 236 and 255.

Choose a user mix: `unit_idGgas_number`

Example: `AG 255` (reconfigures for user mix 255)

Defining a new COMPOSER™ gas mix is faster using serial commands than using the front panel. The basic formula for this is:

`unit_idGM mix_name mix_number gas1_% gas1_number gas2_% gas2_number...↵`

mix_name Use a maximum of 6 letters (upper and/or lower case), numbers and symbols (period or hyphen only). This is equivalent to the short name when creating a mix via the front panel ([page 25](#)).

mix_number Choose a number from 236 to 255. If a user mix with that number already exists, it will be overwritten. Use the number 0 to assign the next available number to your new gas. Gas numbers are assigned in descending order from 255.

gas1_% gas1_number... For each gas, enter its percentage of the mixture up to 2 decimal places, then its gas number ([page 47](#)). 2–5 gases are required, and the sum of all gas constituent percentages must equal 100.00%. After creating a mix, the controller will confirm the new gas:

Example 1: Create a mix of 71.35% helium, 19.25% nitrogen, and 9.4% carbon dioxide as Gas 252, called “MyGas1”.

Command: AGM MyGas1 252 71.35 7 19.25 8 9.4 4↵
Response: A 252 71.35% He 19.25% N2 9.40% CO2

Example 2: Create a mix of 93% methane, 3% ethane, 1% propane, 2% nitrogen, and 1% carbon dioxide, using the next available gas number, called “MyGas2”.

Command: AGM MyGas2 0 93 2 3 5 1 12 2 8 1 4↵
Response: A 253 93.00% CH4 3.00% C2H6 1.00% C3H8 2.00% N2 1.00% CO2

Quick Command Reference

Below is a selection of commonly used serial commands. Serial commands are not case-sensitive, but are presented here as capitalized to help differentiate them from command variables.

General Commands for All Instruments

Change the unit ID: `unit_id@ desired_id↵`
Tare flow: `unit_idV↵`
Tare gauge pressure: `unit_idP↵`
Tare absolute pressure: `unit_idPC↵`
Poll the live data frame: `unit_id↵`
Begin streaming data: `unit_id@@↵`
Stop streaming data: `@@desired_unit_id↵`
Set streaming interval: `unit_idNCS number_of_ms↵`
Query live data info: `unit_id??D*↵`
Manufacturer info: `unit_id??M*↵`
Firmware version: `unit_idVE↵`
Lock the front display: `unit_idL↵`
Unlock the display: `unit_idU↵`

Controller Commands

New setpoint: `unit_idS setpoint_value↵`
Hold valve(s) at current position: `unit_idHP↵`
Hold valve(s) closed: `unit_idHC↵`
Cancel valve hold: `unit_idC↵`
Run Check Control: `unit_id LCRC goto_setpoint collection_time↵`
Optimize Flow: `unit_id LCTCS speed_mode goal_time algorithm↵`

Mass Flow Gas Select™ and COMPOSER™ Commands

Query gas list info: `unit_id??G*↵`
Choose a different gas: `unit_idG gas_number↵`
New COMPOSER mix: `unit_idGM mix_name mix_# gas1_% gas1_# gas2_% gas2_#...↵`
Delete COMPOSER mix: `unit_idGD Mix_#↵`

 This section, and the list above, cover a small selection of the many serial commands that are available. For a more complete listing of serial communication commands, please see the Serial Primer at alicat.com/manuals.

MODBUS RTU Communication

MODBUS is an application-layer messaging protocol that formats data for communications over serial RS-232 or RS-485. The instrument supports MODBUS RTU protocol, with data transmitted through Pin 3 of the DB9 connector.

MODBUS RTU can be used to control:

- taring
- data collection
- setpoint control
- totalizer
- batch dispensing
- changing the gas
- in-device optimization (Autotune)
- control loop adjustment.

For more information on MODBUS RTU communication commands, please see the MODBUS FAQ at alicat.com/using-your-alicat/faq-modbus/ and the MODBUS RTU manual at alicat.com/manuals.

Troubleshooting

If you run into trouble with installation or operation, get in touch with support ([page 2](#)).

General Use

Issue: *The buttons do not work, and the screen shows LCK.*

Action: The flow controller buttons were locked out via a serial command (`unit_idL`). Press and hold all four outer buttons to unlock the interface.

Issue: *I can't read the display easily.*

Action: During the day, you can increase the visibility of the display by increasing the contrast or brightness ([page 31](#)). For monochrome displays under low-light conditions, push the bottom central button (located below the display) to turn on the backlight.

Issue: *The analog output signal indicates values lower than what appears on my instrument's display.*

Action: Analog signal voltage degrades over long distances. You can minimize this effect by using wires with a heavier gauge, especially in the ground wire.

Issue: *How often do I need to calibrate my instrument?*

Action: Annual recalibration is recommended. Check your instrument's last calibration date by selecting **MENU** → **ABOUT** → **About Device**. If it is time to recalibrate, request a recalibration at alicat.com/service.

Issue: *I dropped my instrument. Is it OK? Do I need to recalibrate?*

Action: If it turns on and appears to respond normally, then it is probably OK. It may or may not need a recalibration. Give it a tare ([page 12](#)), and compare it against a known good flow standard. If it checks out, keep using it, but tell us about the drop at your next annual recalibration so we can check it out for you.

Issue: *How can I see readings in different units?*

Action: From the main menu, select **SETUP** → **Sensor** → **Engineering Units**. From this menu, you can adjust any variable's units. For more information, see [page 26](#).

Issue: *My controller won't reach its setpoint.*

Action: This is often caused by not enough supply pressure in the system. Increasing the inlet pressure regularly fixes this issue.

If increasing the pressure doesn't help, check to see if there is a clog. Teflon tape can often get stuck in the flow channel and block flow. Clean out any loose Teflon tape and never tape the first two threads entering the instrument to help avoid this issue.

Flow Readings

Issue: *The live readings won't settle down.*

Action: The instrument is very fast, so it can detect subtle variations in flow that may go unnoticed by your other instruments. This sensitivity can help detect problems with pumps or flow controllers. Use the optimization (Autotune) function to improve performance ([page 21](#)). See [page 22](#) for a quick guide on control checks.

Issue: *My flow readings are negative.*

Action: Under conditions of no flow, a negative flow reading can indicate a poor tare. If using a controller, ensure that auto tare is enabled and give the controller a zero setpoint for at least 2 seconds. For meters, ensure a no flow condition, then press the **TARE** button.

Issue: *My instrument does not agree with another flow instrument I have in line.*

Action: Check the STP or NTP settings (**MENU** → **SETUP** → **Sensor** → **STP / NTP Flow Ref**) to ensure that your standardized temperature and pressure references match those of your other flow calibrator. Also check that your instrument's Gas Select™ is set to the right gas or mixture.

Issue: *My flow readings won't change when flow changes.*

Action: If your flow readings won't change regardless of actual flow, your flow sensor may be damaged. Please contact support to troubleshoot ([page 2](#)).

Mass Flow Instruments

Issue: *Can I use my mass flow instrument with other gases?*

Action: Yes. Mass flow instruments are designed to work with many different gases. Gas Select™ includes up to 130 preloaded gases and gas mixes ([page 25](#)). You can also define your own mixture using COMPOSER™ ([page 25](#)).

Pressure Readings

Issue: *My pressure readings are negative.*

Action: If a negative reading is not expected, your instrument may need to be tared ([page 12](#)). Ensure a gauge pressure sensor (or an absolute pressure sensor with an optional barometer) is open to the ambient atmosphere before taring. A differential pressure sensor should be exposed to a common pressure on both ports before taring.

Issue: *My pressure readings jump to zero when pressures are low.*

Action: Your instrument is equipped with a programmable zero band that is preset at the factory. Reduce your deadband threshold by selecting **SETUP** → **Sensor** → **Zero Band**.

Issue: *My pressure instrument disagrees with another instrument I have in line.*

Action: Pressure instruments can normally be compared against one another provided there are no leaks between the two instruments. Another possibility is an improper tare error ([page 12](#)).

Issue: *Can I use my pressure instrument with other gases or liquids?*

Action: Yes for gases, maybe for liquids. Pressure instruments are designed to operate independent of the media being used.

One thing to check before changing gases or liquids is the chemical and material compatibility of the gas being used with the wetted materials inside the controller. We also recommend contacting support ([page 2](#)) before switching a gas pressure instrument over to liquid pressure instrument as some modification may be necessary.

Liquid Instruments

Issue: *Can I use the meter with other liquids?*

Action: No. Your flow meter is designed specifically to work with only one liquid, typically water. For use with a different liquid, the instrument will require recalibration. Please contact us to submit a service request at alicat.com/service.

Serial Communications

Issue: *I can't communicate to the instrument when it is connected to my PC.*

Action: **1.** Make sure your software, COM port, and instrument use the same baud rate (**MENU** → **SETUP** → **RS-232 Serial or RS-485 Serial** → **Baud Rate**).

2. Check the unit ID (**MENU** → **SETUP** → **RS-232 Serial or RS-485 Serial** → **Unit ID**) to make sure you are addressing it properly with your serial commands.

3. Make sure the COM number matches the one your software is using to connect to the instrument.

4. On the external serial communications instrument (computer, PLC, etc.), Be sure that the flow control (handshaking) settings are set as on [page 33](#).

5. Check the pinout of your instrument to confirm the connection is on the right pin ([page 43](#)).



Still experiencing issues? Please contact support. See [page 2](#).

Maintenance



Warning: Do not attempt to disconnect this instrument from any system which has been pressurized without independently confirming that all pressure has been safely released and that any hazardous gases which remain in that system have been purged.

Cleaning

Mass flow and **pressure instruments** do not require cleaning, provided that they flow clean, dry gas.

Liquid instruments should have filters in place to remove particulates or biological materials that may grow in the instrument. When removing liquid instruments from the line for an extended period of time, remove all liquid from the instrument to ensure no deposits of calcium or other soluble minerals can affect the instrument.

If necessary, the outside of any instrument can be cleaned with a soft dry cloth.



Warning: If you suspect that debris or other foreign material has entered your instrument, do not take apart the flow body to clean it. Please contact support for cleaning ([page 2](#)).

Repair

If you find your instrument has malfunctioned in some way or appears to no longer work as intended, please contact Alicat support ([page 2](#)) to perform maintenance. This instrument may only be serviced by certified Alicat personnel. Any attempt to improperly dismantle and repair the instrument may void the warranty and may cause further instrument failure.

Recalibration

The recommended period for recalibration is once every year. A label located on the back of the instrument lists the most recent calibration date. This date is also stored inside your flow controller and is visible by selecting **MENU** → **ABOUT** → **About Device**. When it is time for your instrument's annual recalibration, fill out the service request form at alicat.com/service.

Appendix A: Pinouts

Check the calibration data sheet and pinout for your instrument.

See [page 33](#) for additional important information about connecting your instrument to a computer for serial commands. Individual pinouts available at alicat.com/pinout. The availability of different output signals depend on the options ordered.

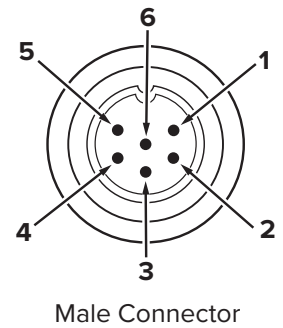
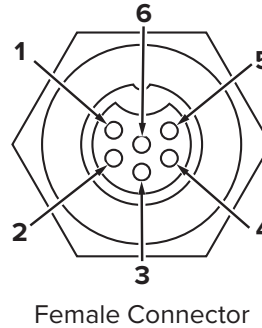
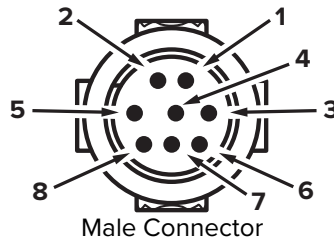
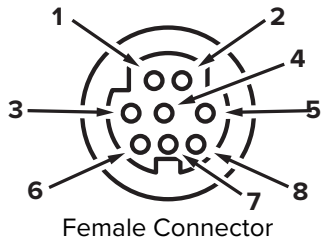

8-Pin Mini-DIN (Default)

Pin	Function
1	Not Connected <i>Optional: 4–20 mA primary output signal</i>
2	Static 5.12 Vdc <i>Optional: secondary analog output (4–20 mA, 0–5 Vdc, 1–5 Vdc, 0–10 Vdc) or basic alarm</i>
3	Serial RS-232 RX (receive input) / RS-485 B(+)
4	Analog Setpoint Input (Controllers) Remote Tare (Meters and Gauges)
5	Serial RS-232 TX (send output) / RS-485 A(-)
6	0–5 Vdc Analog Out <i>Optional: 1–5 Vdc or 0–10 Vdc output signal</i>
7	Power In
8	Ground (common for power, digital communications, analog signals, and alarms)

Warning: Do not connect power to pins 1 through 6, as permanent damage can occur. It is common to mistake pin 2 (labeled 5.12 Vdc Output) as the standard 0–5 Vdc analog output signal. Pin 2 is normally a constant 5.12 Vdc.

Locking Industrial Connector Pinout

Pin	Function
1	Power In
2	Serial RS-232 TX (send output) / RS-485 A(-)
3	Serial RS-232 RX (receive input) / RS-485 B(+)
4	Analog Setpoint Input (Controllers) Remote Tare (Meters and Gauges)
5	Ground (common for power, digital communications, analog signals, and alarms)
6	Analog Out (voltage or current as ordered)

9-Pin D-Sub Connector Common Pinouts

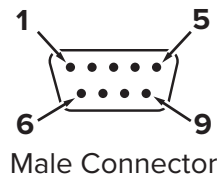
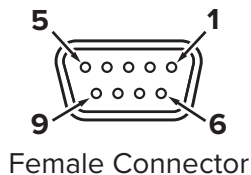

Pin	DB9 (F) DB9M (M)	DB9A and DB9K	DB9R	DB9T	DB9U	DB9B	DB9G	DB9H	DB9I	DB9N
1	Analog Current	NC	TX or A	TX or A	RX or B	Analog Out 2	RX or B	TX or A	NC	Power In
2	Analog Out 2	Analog Out	Analog Out	Analog Out	Analog Out	Analog Out	Analog Out	Analog Out	Analog Out	Analog In
3	RX or B	Power In	Analog In	Power In	Power In	Power In	Ground	Analog In	Power In	Analog Out
4	Analog In	Ground	Ground	Ground	Ground	Ground	Power In	RX or B	Ground	NC
5	TX or A	TX or A	NC	NC	NC	Ground	Ground	Analog Out 2	NC	Ground
6	Analog Out	Analog In	RX or B	Analog In	Analog In	Analog In	TX or A	NC	Analog In	Ground
7	Power In	Ground	Power In	Ground	Ground	Ground	Analog In	Power In	Ground	RX or B
8	Ground	Ground	Ground	Ground	Ground	TX or A	Analog Current	Ground	RX or B	TX or A
9	Ground	RX or B	Ground	RX or B	TX or A	RX or B	Ground	Ground	TX or A	NC

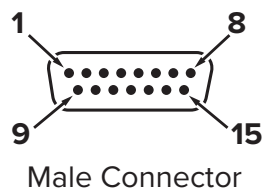
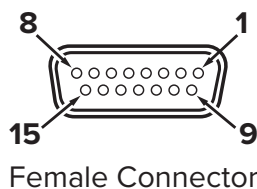

15-Pin D-Sub Connector Common Pinouts

Pin	DB15	DB15A	DB15B	DB15H	DB15K	DB15O	DB15S
1	Ground	Ground	Ground	NC	NC	Ground	Ground
2	Analog Out	Analog Out	Analog Out	RX or B	Analog Out	NC	Analog Out
3	Ground	Analog In	Ground	NC	NC	Ground	NC
4	NC	Ground	NC	NC	NC	Analog Out	NC
5	Power In	Ground	Power In	Ground	Ground	Power In	Ground
6	NC	Ground	NC	Analog Out	NC	NC	NC
7	NC	Power In	NC	Ground	Power In	Analog In	NC
8	Analog In	TX or A	Analog In	NC	Analog In	NC5	Analog In
9	Ground	Ground	Ground	NC	Analog Out 2	Ground	Ground
10	Ground	NC	Ground	Analog Out 2	NC	Ground	Ground
11	Analog Out 2	NC	Analog Out 2	Power In	Ground	Analog Out 2	Analog Out 2
12	NC	Analog Out 2	NC	Ground	Ground	NC	RX or AB
13	RX or B	NC	NC	NC	RX or B	NC	Power In
14	Ground	NC	RX or A	Analog In	TX or B	RX or A	TX or A
15	TX or A	RX or B	TX or A	TX or A	Ground	TX or A	Ground

Key of Terms:

Analog In

Analog setpoint input for controllers **Ground to Tare** on meters and gauges

Analog Out

0–5 Vdc output signal (1–5, 0–10 Vdc optional)

Analog Out 2

5.12 Vdc or optional secondary analog output

Analog Current

Not connected by default. If not present, **Analog Out** includes current. Optional 4–20 mA analog output signal

NC

Not connected

Power In

(+Vdc)

RX or B

Serial RS-232 RX or RS-485 (+)

TX or A

Serial RS-232 TX or RS-485 (-)

Ground

Common for power, digital communications, analog signals, alarms

M12 Connector Common Pinouts

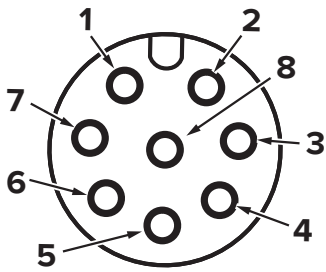

Female Connector

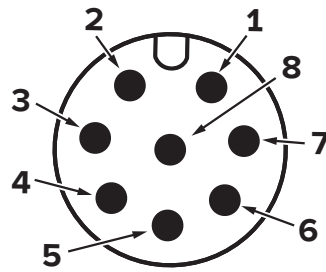

Male Connector

Pin	M12	M12MD
1	0–5 Vdc Output Signal <i>Optional: 1–5 or 0–10 Vdc</i>	Not Connected <i>Optional: 4–20 mA primary output signal</i>
2	Power In	Static 5.12 Vdc <i>Optional: Secondary analog output (4–20 mA, 0–5 Vdc, 1–5 Vdc, 0–10 Vdc) or basic alarm</i>
3	Serial RS-232 RX (receive input) / RS-485(-)	Serial RS-232 RX (receive input) / RS-485(-)
4	Analog Setpoint Input (Controllers) Ground to Tare (Meters and Gauges)	Analog Setpoint Input (Controllers) Ground to Tare (Meters and Gauges)
5	Serial RS-232 TX (send output) / RS-485(+)	Serial RS-232 TX (send output) / RS-485(+)
6	Static 5.12 Vdc <i>Optional: Secondary analog output (4–20 mA, 0–5 Vdc, 1–5 Vdc, 0–10 Vdc) or basic alarm</i>	0–5 Vdc Output Signal <i>Optional: 1–5 Vdc or 0–10 Vdc</i>
7	Ground (common for power, digital communications, analog signals, and alarms)	Power in
8	Inactive <i>Optional: 4–20 mA primary output signal</i>	Ground (common for power, digital communications, analog signals, and alarms)

Appendix B: Reference Information

Engineering Units

For more information on engineering units, see the engineering units section ([page 26](#)).

Pressure Units

Absolute or Barometric	Gauge	Notes
PaA	PaG	Pascal
hPaA	hPaG	Hectopascal
kPaA	kPaG	Kilopascal
MPaA	MPaG	Megapascal
mbarA	mbarG	Millibar
barA	barG	Bar
g/cm ² A	g/cm ² G	Gram force per square centimeter [†]
kg/cm ² A	kg/cm ² G	Kilogram force per square centimeter*
PSIA	PSIG	Pound force per square inch
PSFA	PSFG	Pound force per square foot
mTorrA	mTorrG	Millitorr
torrA	torrG	Torr
mmHgA	mmHgG	Millimeter of mercury at 0°C
inHgA	inHgG	Inch of mercury at 0°C
mmH ₂ O A	mmH ₂ O G	Millimeter of water at 4°C (NIST conventional) [†]
mmH ₂ O A	mmH ₂ O G	Millimeter of water at 60°C [†]
cmH ₂ O A	cmH ₂ O G	Centimeter of water at 4°C (NIST conventional) [†]
cmH ₂ O A	cmH ₂ O G	Centimeter of water at 60°C [†]
inH ₂ O A	inH ₂ O G	Inch of water at 4°C (NIST conventional) [†]
inH ₂ O A	inH ₂ O G	Inch of water at 60°C [†]
atm		Atmosphere
m asl		Meter above sea level
ft asl		Foot above sea level
V		Volt
count	count	Setpoint count, 0–64000
%	%	Percent of full scale

Flow Units

Volumetric	Standard	Normal	Notes
μL/m	SμL/m	NμL/m	Microliter per minute [‡]
mL/s	SmL/s	NmL/s	Milliliter per second
mL/m	SmL/m	NmL/m	Milliliter per minute
mL/h	SmL/h	NmL/h	Milliliter per hour
L/s	SL/s	NL/s	Liter per second
LPM	SLPM	NLPM	Liter per minute
L/h	SL/h	NL/h	Liter per hour
US GPM			US gallon per minute
US GPH			US gallon per hour
CCS	SCCS	NCCS	Cubic centimeter per second
CCM	SCCM	NCCM	Cubic centimeter per minute
cm ³ /h	Scm ³ /h	Ncm ³ /h	Cubic centimeter per hour [†]
m ³ /m	Sm ³ /m	Nm ³ /m	Cubic meter per minute [†]
m ³ /h	Sm ³ /h	Nm ³ /h	Cubic meter per hour [†]
m ³ /d	Sm ³ /d	Nm ³ /d	Cubic meter per day [†]
in ³ /m	Sin ³ /m		Cubic inch per minute [†]
CFM	SCFM		Cubic foot per minute
CFH	SCFH		Cubic foot per hour
CFD	SCFD		Cubic foot per day
	kSCFM		1000 cubic feet per minute
count	count	count	Setpoint count, 0–64000
%	%	%	Percent of full scale

True Mass Flow Units

Label	Notes
mg/s	Milligram per second
mg/m	Milligram per minute
g/s	Gram per second
g/m	Gram per minute
g/h	Gram per hour
kg/m	Kilogram per minute
kg/h	Kilogram per hour
oz/s	Ounce per second
oz/m	Ounce per minute
lb/m	Pound per minute
lb/h	Pound per hour

Total Units

Label	Notes
μL	MicroLiter [‡]
mL	Milliliter
L	Liter
US GAL	US gallon
cm ³	Cubic centimeter [†]
m ³	Cubic meter [†]
in ³	Cubic inch [†]
ft ³	Cubic foot [†]
μP	Micropoise, a measure of viscosity*
mg	Milligrams
g	Grams
kg	Kilograms
oz	US ounces
lb	US pounds

Temperature Units

Label	Notes
°C	Degrees Celsius
°F	Degrees Fahrenheit
K	Kelvin
°R	Degrees Rankine

Time Units

Label	Notes
ms	Milliseconds
s	Seconds
m	Minutes
hour	Hours
day	Days

* Displayed as kg/cmA and kg/cmG.

† Superscript and subscript numerals are displayed as lining (normal) numerals.

‡ Instances of μ are displayed as a lower-case u.

Gas List by Number

To use any of these gases in your instrument, use Gas Select™ (page 25).

#	ShortName	Long Name
0	Air	Air (Clean Dry)
1	Ar	Argon
2	CH ₄	Methane
3	CO	Carbon Monoxide
4	CO ₂	Carbon Dioxide
5	C ₂ H ₆	Ethane
6	H ₂	Hydrogen
7	He	Helium
8	N ₂	Nitrogen
9	N ₂ O	Nitrous Oxide
10	Ne	Neon
11	O ₂	Oxygen
12	C ₃ H ₈	Propane
13	nC ₄ H ₁₀	Normal Butane
14	C ₂ H ₂	Acetylene
15	C ₂ H ₄	Ethylene (Ethene)
16	iC ₄ H ₁₀	Isobutane
17	Kr	Krypton
18	Xe	Xenon
19	SF ₆	Sulfur Hexafluoride ¹
20	C-25	25% CO ₂ , 75% Ar
21	C-10	10% CO ₂ , 90% Ar
22	C-8	8% CO ₂ , 92% Ar
23	C-2	2% CO ₂ , 98% Ar
24	C-75	75% CO ₂ , 25% Ar
25	He-25	25% He, 75% Ar
26	He-75	75% He, 25% Ar
27	A1025	90% He, 7.5% Ar, 2.5% CO ₂
28	Star29	Stargon CS (90% Ar, 8% CO ₂ , 2% O ₂)
29	P-5	5% CH ₄ , 95% Ar
30	NO	Nitric Oxide ²
31	NF ₃	Nitrogen Trifluoride ²
32	NH ₃	Ammonia ²
33	Cl ₂	Chlorine ²
34	H ₂ S	Hydrogen Sulfide ²
35	SO ₂	Sulfur Dioxide ²
36	C ₃ H ₆	Propylene ²
80	1Buten	1-Butylene ²
81	cButen	Cis-Butene (cis-2-Butene) ²
82	iButen	Isobutene ²
83	tButen	Trans-2-Butene ²
84	COS	Carbonyl Sulfide ²
85	DME	Dimethylether (C ₂ H ₆ O) ²
86	SiH ₄	Silane ²
100	R-11	Trichlorofluoromethane (CCl ₃ F) ^{2,3}
101	R-115	Chloropentafluoroethane (C ₂ ClF ₅) ^{2,3}
102	R-116	Hexafluoroethane (C ₂ F ₆) ²
103	R-124	Chlorotetrafluoroethane (C ₂ HClF ₄) ^{2,3}

#	ShortName	Long Name
104	R-125	Pentafluoroethane (CF ₃ CHF ₂) ^{2,3}
105	R-134A	Tetrafluoroethane (CH ₂ FCF ₃) ^{2,3}
106	R-14	Tetrafluoromethane (CF ₄) ²
107	R-142b	Chlorodifluoroethane (CH ₃ CClF ₂) ^{2,3}
108	R-143a	Trifluoroethane (C ₂ H ₃ F ₃) ^{2,3}
109	R-152a	Difluoroethane (C ₂ H ₄ F ₂) ²
110	R-22	Difluoromonochloromethane (CHClF ₂) ^{2,3}
111	R-23	Trifluoromethane (CHF ₃) ^{2,3}
112	R-32	Difluoromethane (CH ₂ F ₂) ^{2,3}
113	R-318	Octafluorocyclobutane (C ₄ F ₈) ²
114	R-404A	44% R-125, 4% R-134A, 52% R-143A ^{2,3}
115	R-407C	23% R-32, 25% R-125, 52% R-143A ^{2,3}
116	R-410A	50% R-32, 50% R-125 ^{2,3}
117	R-507A	50% R-125, 50% R-143A ^{2,3}
140	C-15	15% CO ₂ , 85% Ar
141	C-20	20% CO ₂ , 80% Ar
142	C-50	50% CO ₂ , 50% Ar
143	He-50	50% He, 50% Ar
144	He-90	90% He, 10% Ar
145	Bio5M	5% CH ₄ , 95% CO ₂
146	Bio10M	10% CH ₄ , 90% CO ₂
147	Bio15M	15% CH ₄ , 85% CO ₂
148	Bio20M	20% CH ₄ , 80% CO ₂
149	Bio25M	25% CH ₄ , 75% CO ₂
150	Bio30M	30% CH ₄ , 70% CO ₂
151	Bio35M	35% CH ₄ , 65% CO ₂
152	Bio40M	40% CH ₄ , 60% CO ₂
153	Bio45M	45% CH ₄ , 55% CO ₂
154	Bio50M	50% CH ₄ , 50% CO ₂
155	Bio55M	55% CH ₄ , 45% CO ₂
156	Bio60M	60% CH ₄ , 40% CO ₂
157	Bio65M	65% CH ₄ , 35% CO ₂
158	Bio70M	70% CH ₄ , 30% CO ₂
159	Bio75M	75% CH ₄ , 25% CO ₂
160	Bio80M	80% CH ₄ , 20% CO ₂
161	Bio85M	85% CH ₄ , 15% CO ₂
162	Bio90M	90% CH ₄ , 10% CO ₂
163	Bio95M	95% CH ₄ , 5% CO ₂
164	EAN-32	32% O ₂ , 68% N ₂
165	EAN-36	36% O ₂ , 64% N ₂
166	EAN-40	40% O ₂ , 60% N ₂
167	HeOx20	20% O ₂ , 80% He
168	HeOx21	21% O ₂ , 79% He
169	HeOx30	30% O ₂ , 70% He
170	HeOx40	40% O ₂ , 60% He
171	HeOx50	50% O ₂ , 50% He
172	HeOx60	60% O ₂ , 40% He

#	ShortName	Long Name
173	HeOx80	80% O ₂ , 20% He
174	HeOx99	99% O ₂ , 1% He
175	EA-40	Enriched Air-40% O ₂
176	EA-60	Enriched Air-60% O ₂
177	EA-80	Enriched Air-80% O ₂
178	Metab	Metabolic Exhalant (16% O ₂ , 78.04% N ₂ , 5% CO ₂ , 0.96% Ar)
179	LG-4.5	4.5% CO ₂ , 13.5% N ₂ , 82% He
180	LG-6	6% CO ₂ , 14% N ₂ , 80% He
181	LG-7	7% CO ₂ , 14% N ₂ , 79% He
182	LG-9	9% CO ₂ , 15% N ₂ , 76% He
183	HeNe-9	9% Ne, 91% He
184	LG-9.4	9.4% CO ₂ , 19.25% N ₂ , 71.35% He
185	SynG-1	40% H ₂ , 29% CO, 20% CO ₂ , 11% CH ₄
186	SynG-2	64% H ₂ , 28% CO, 1% CO ₂ , 7% CH ₄
187	SynG-3	70% H ₂ , 4% CO, 25% CO ₂ , 1% CH ₄
188	SynG-4	83% H ₂ , 14% CO, 3% CH ₄
189	NatG-1	93% CH ₄ , 3% C ₂ H ₆ , 1% C ₃ H ₈ , 2% N ₂ , 1% CO ₂
190	NatG-2	95% CH ₄ , 3% C ₂ H ₆ , 1% N ₂ , 1% CO ₂
191	NatG-3	95.2% CH ₄ , 2.5% C ₂ H ₆ , 0.2% C ₃ H ₈ , 0.1% C ₄ H ₁₀ , 1.3% N ₂ , 0.7% CO ₂
192	CoalG	50% H ₂ , 35% CH ₄ , 10% CO, 5% C ₂ H ₄
193	Endo	75% H ₂ , 25% N ₂
194	HHO	66.67% H ₂ , 33.33% O ₂
195	HD-5	LPG: 96.1% C ₃ H ₈ , 1.5% C ₂ H ₆ , 0.4% C ₃ H ₆ , 1.9% n-C ₄ H ₁₀
196	HD-10	LPG: 85% C ₃ H ₈ , 10% C ₃ H ₆ , 5% n-C ₄ H ₁₀
197	OCG-89	89% O ₂ , 7% N ₂ , 4% Ar
198	OCG-93	93% O ₂ , 3% N ₂ , 4% Ar
199	OCG-95	95% O ₂ , 1% N ₂ , 4% Ar
200	FG-1	2.5% O ₂ , 10.8% CO ₂ , 85.7% N ₂ , 1% Ar
201	FG-2	2.9% O ₂ , 14% CO ₂ , 82.1% N ₂ , 1% Ar
202	FG-3	3.7% O ₂ , 15% CO ₂ , 80.3% N ₂ , 1% Ar
203	FG-4	7% O ₂ , 12% CO ₂ , 80% N ₂ , 1% Ar
204	FG-5	10% O ₂ , 9.5% CO ₂ , 79.5% N ₂ , 1% Ar
205	FG-6	13% O ₂ , 7% CO ₂ , 79% N ₂ , 1% Ar
206	P-10	10% CH ₄ , 90% Ar
210	D-2	Deuterium

¹ Sulfur hexafluoride is a highly potent greenhouse gas monitored under the Kyoto Protocol.

² Corrosive-resistant units only

³ Under the Montreal Protocol and Kigali Amendment, the production and consumption of these ozone-depleting substances (ODS) is being or has been phased out. It is recommended you ensure compliance with this universally ratified treaty before attempting to use these gases, in addition to R113, R-123, and R-141b.

Gas List by Category

See previous page for Gas Select™ index numbers.

Pure Non-Corrosive Gases

Acetylene (C₂H₂)
Air (clean, dry)
Argon (Ar)
Isobutane (i-C₄H₁₀)
Normal Butane (n-C₄H₁₀)
Carbon dioxide (CO₂)
Carbon monoxide (CO)
Deuterium (D₂)
Ethane (C₂H₆)
Ethylene (Ethene) (C₂H₄)
Helium (He)
Hydrogen (H₂)
Krypton (Kr)
Methane (CH₄)
Neon (Ne)
Nitrogen (N₂)
Nitrous Oxide (N₂O)
Oxygen (O₂)
Propane (C₃H₈)
Sulfur Hexafluoride (SF₆)¹
Xenon (Xe)

Breathing Gases

Metabolic Exhalant
EAN-32
EAN-36
EAN-40
EA-40
EA-60
EA-80
Heliox-20
Heliox-21
Heliox-30
Heliox-40
Heliox-50
Heliox-60
Heliox-80
Heliox-99

Bioreactor Gas Mixes

5%–95% CH₄/CO₂ in 5% increments

Refrigerants²

R-11³
R-14
R-22³
R-23³
R-32³
R-115³
R-116
R-124³
R-125³
R-134a³
R-142b³
R-143a³
R-152a
R-318
R-404A³
R-407C³
R-410A³
R-507A³

Welding Gases

C-2
C-8
C-10
C-15
C-20
C-25
C-50
C-75
He-25
He-50
He-75
He-90
A 1025
Stargon CS

Chromatography Gas Mixes

P-5
P-10

Oxygen Concentrator Gas Mixes

89% O₂, 7.0% N₂, 4.0% Ar
93% O₂, 3.0% N₂, 4.0% Ar
95% O₂, 1.0% N₂, 4.0% Ar

Stack/Flue Gas Mixes

2.5% O₂, 10.8% CO₂, 85.7% N₂, 1.0% Ar
2.9% O₂, 14% CO₂, 82.1% N₂, 1.0% Ar
3.7% O₂, 15% CO₂, 80.3% N₂, 1.0% Ar
7.0% O₂, 12% CO₂, 80% N₂, 1.0% Ar
10% O₂, 9.5% CO₂, 79.5% N₂, 1.0% Ar
13% O₂, 7.0% CO₂, 79% N₂, 1.0% Ar

Laser Gas Mixes

4.5% CO₂, 13.5% N₂, 82% He
6.0% CO₂, 14% N₂, 80% He
7.0% CO₂, 14% N₂, 79% He
9.0% CO₂, 15% N₂, 76% He
9.4% CO₂, 19.25% N₂, 71.35% He
9.0% Ne, 91% He

Fuel Gas Mixes

Coal Gas 50% H₂, 35% CH₄, 10% CO, 5% C₂H₄
Endothermic Gas 75% H₂, 25% N₂
HHO 66.67% H₂, 33.33% O₂
LPG HD-5 96.1% C₃H₈, 1.5% C₂H₆, 0.4% C₃H₆, 1.9% n-C₄H₁₀
LPG HD-10 85% C₃H₈, 10% C₃H₆, 5% n-C₄H₁₀

Natural Gases

93.0% CH₄, 3.0% C₂H₆, 1.0% C₃H₈, 2.0% N₂, 1.0% CO₂
95.0% CH₄, 3.0% C₂H₆, 1.0% N₂, 1.0% CO₂
95.2% CH₄, 2.5% C₂H₆, 0.2% C₃H₈, 0.1% C₄H₁₀, 1.3% N₂, 0.7% CO₂

Synthesis Gases

40% H₂, 29% CO, 20% CO₂, 11% CH₄
64% H₂, 28% CO, 1.0% CO₂, 7.0 CH₄
70% H₂, 4.0% CO, 25% CO₂, 1.0% CH₄
83% H₂, 14% CO, 3.0% CH₄

Pure Corrosive Gases²

Ammonia (NH₃)
Butylene (1-Buten)
Cis-Butene (c-Buten)
Isobutene (i-Buten)
Trans-Butene (t-Buten)
Carbonyl Sulfide (COS)
Chlorine (Cl₂)
Dimethylether (DME)
Hydrogen Sulfide (H₂S)
Nitrogen Trifluoride (NF₃)
Nitric Oxide (NO)
Propylene (C₃H₆)
Silane (SiH₄)
Sulfur Dioxide (SO₂)

¹ Sulfur hexafluoride is a highly potent greenhouse gas monitored under the Kyoto Protocol.

² Corrosive-resistant units only

³ Under the Montreal Protocol and Kigali Amendment, the production and consumption of these ozone-depleting substances (ODS) is being or has been phased out. It is recommended you ensure compliance with this universally ratified treaty before attempting to use these gases, in addition to R113, R-123, and R-141b.

Appendix C: Application Setup

MCV Controller Operating Notes

Alicat's MCV mass flow controller is equipped with an integrated Swagelok® positive shutoff valve. This valve is normally closed, but can be opened by supplying 60–120 PSIG of air pressure. The shut-off valve closes again when this pressure is reduced below 60 PSIG.

A common method for actuating the shutoff valve incorporates a three-way solenoid valve (shown to the right). Pressure is applied to one side of the solenoid valve while the other side of the solenoid is left open to atmosphere. When the solenoid is energized, pressure is delivered to the shutoff valve, causing it to open. When the solenoid is returned to a relaxed state, the gas vents to atmosphere, allowing the shut-off valve to close.



MCV-1SLPM-D mass flow controller.

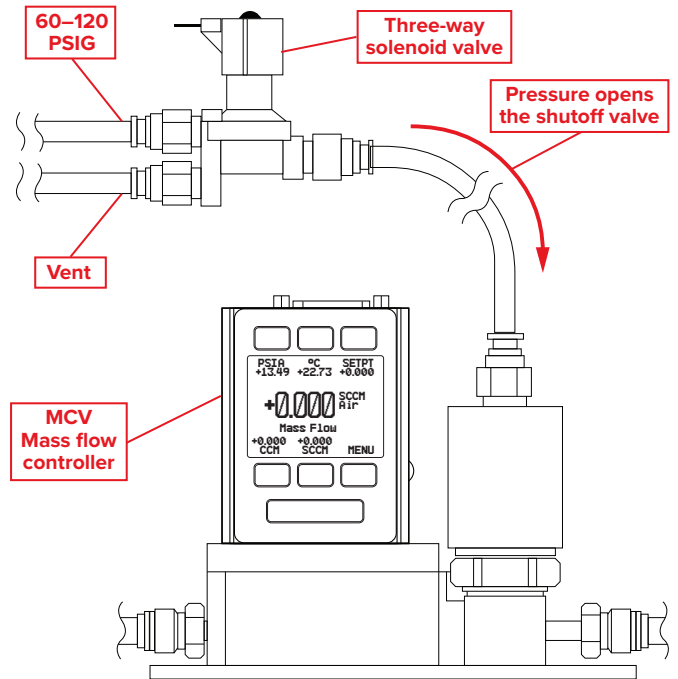

Typical MCV configuration.

Pressure Controller Applications

Forward (Downstream) Pressure Control

When the valve is located on the upstream side (direct control), the sensor controls pressure downstream. This configuration follows our standard pressure control algorithm. The valve opens to increase pressure, and closes to decrease pressure.

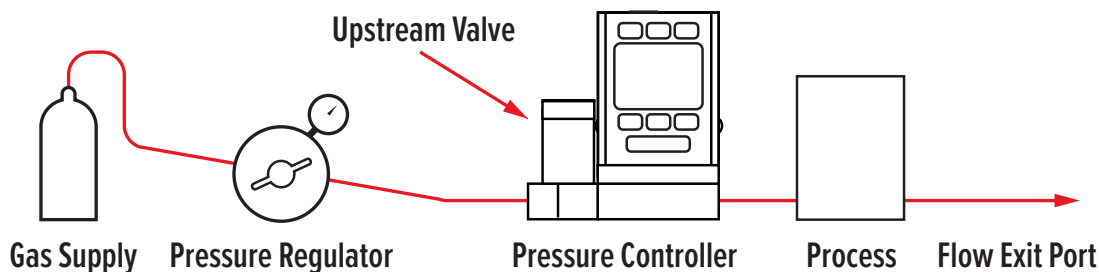

Back Pressure Control

When the valve is located on the downstream side (inverse control), the sensor controls pressure upstream. This configuration is referred to as a back pressure controller. This configuration follows our inverse pressure control algorithm. The valve closes to increase pressure, and opens to decrease pressure.

Note: Back pressure controllers include "DS," for downstream valve, in their part codes.

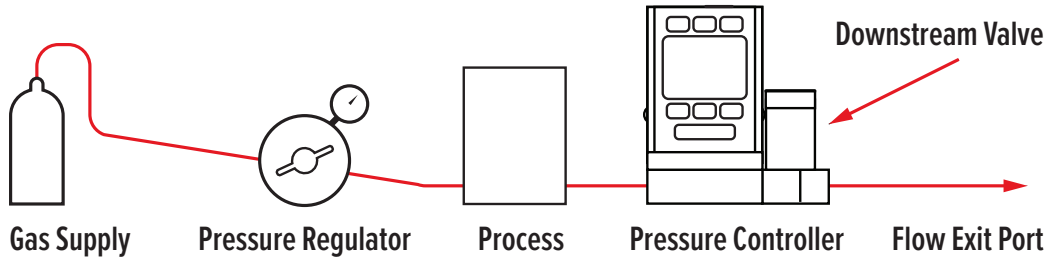

Dual Valve Pressure Control

The port on the face of the PCD unit is connected to the closed volume you want to control pressure in. The valve on the supply side opens to increase the pressure in the closed volume, and the valve on the exhaust side opens to decrease pressure.

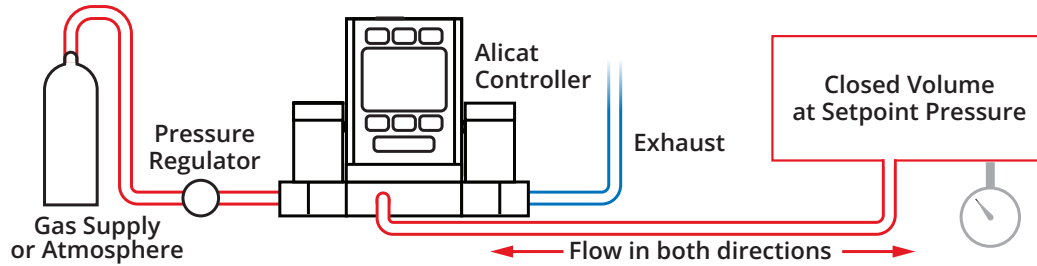

Differential Pressure Control

Differential pressure controllers have two ports for connecting to points in the system where the differential pressure is measured. The upstream port is for the higher pressure, and the downstream port is for the lower pressure. In these devices, the differential pressure ports have no flow and are not connected to the flow path. A PCD-Series is used in closed volume applications.

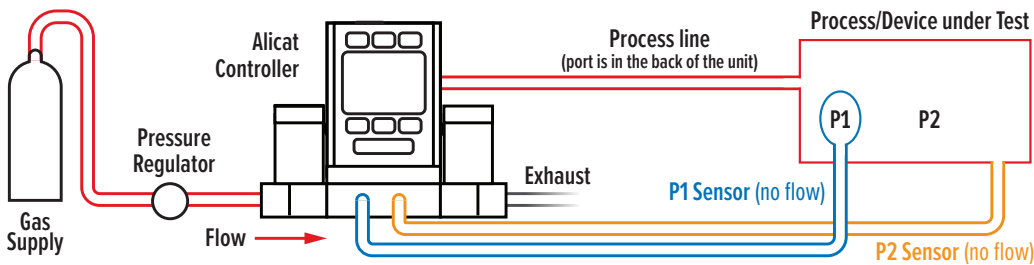

15PSID pressure controller with two differential pressure detector ports in front and a DB-9 serial connector.

Remote-Sensing Controller

The PC3-Series senses and controls the pressure at a point in the system outside of the pressure controller itself. All PC-Series controllers can be ordered with an additional NPT port that connects to the pressure sensor in the device. The pressure sensor is isolated from the flow path within the device. The PCD3-Series is used for closed volumes.

PC3 Controller:

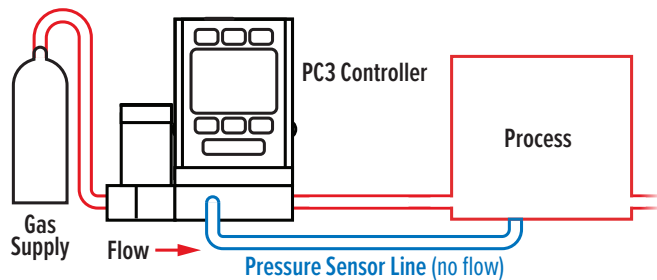

PCD3 Controller:

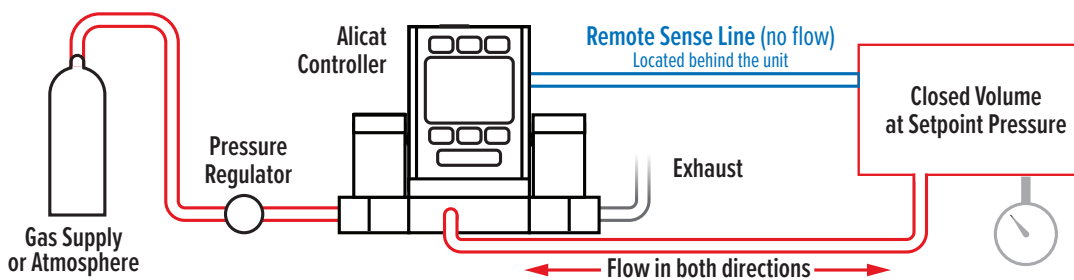

PC3-Series 15PSIG pressure controller with remote sensing port in front, and mini-DIN serial connector.

Integrated Vacuum Controllers (IVC)

IVC and IVCD devices are used in applications where precise control of vacuum is required, and are available in 10 TorrA, 100 TorrA, or 1000 TorrA sensors. The IVC and IVCD-Series are similar to the PC and PCD absolute pressure controllers in functionality and in the navigation menus available on the screen.

Integration of the vacuum sensor, control valve, and PID algorithm in a single device eliminates the need for an external vacuum sensor and throttle valve in your system. These devices can have SAE ports, compression ports, VCR®-compatible fittings, or VCO®-compatible fittings. Process port sizes may change depending on the valve on your device.

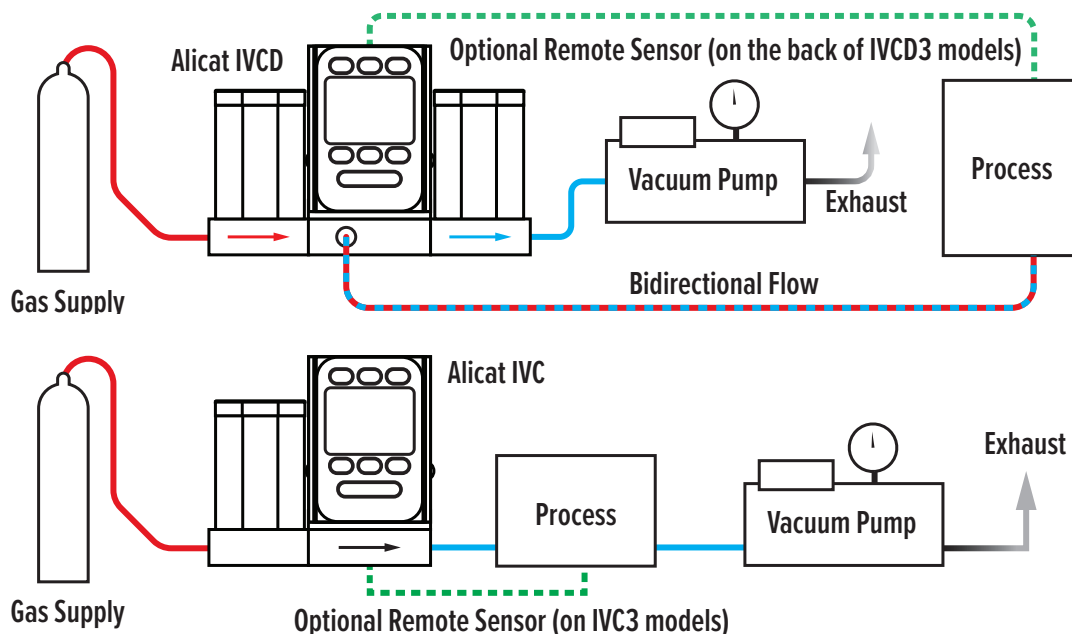

IVC-Series absolute (vacuum) pressure controller.